

PAY 300 AJ

Armătură de sertizat, DKJ

Caracteristici

Racord 1	Filete UN/UNF de piuliță
Formă de etanșare 1	Con interior 74°
Prescurtare	DKJ
Standard	ISO 8434-2
Set de livrare	Niplu de presare + montură presată
Material	Oțel
Protecția suprafeței	acoperire galvanică

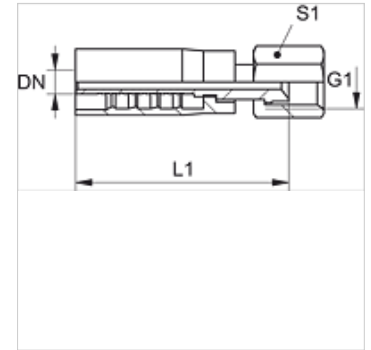

Articol

Denumire	DN	Dimensiune	Țol	G1	L1 (mm)	S1
PAY 306 AJ	6	4	1/4"	7/16" -20 UNF	-	-
PAY 306 AJ 08	6	4	1/4"	1/2" -20 UNF	55,0	19
PAY 310 AJ	10	6	3/8"	9/16" -18 UNF	59,0	22
PAY 310 AJ 13	10	6	3/8"	3/4" -16 UNF	59,0	24
PAY 313 AJ	12	8	1/2"	3/4" -16 UNF	64,0	27
PAY 313 AJ 16	12	8	1/2"	7/8" -14 UNF	62,0	27
PAY 316 AJ	16	10	5/8"	7/8" -14 UNF	73,0	27
PAY 320 AJ	19	12	3/4"	1.1/16" -12 UN	79,0	36
PAY 325 AJ	25	16	1"	1.5/16" -12 UN	77,0	41
PAY 325 AJ 32	25	16	1"	1.5/8" -12 UN	75,0	50
PAY 332 AJ	31	20	1.1/4"	1.5/8" -12 UN	-	-