

PN AFL 45

Niplu de sertizat, DKL 45°

HANSA FLEX

Caracteristici

Domeniul de utilizare	niplu de presare pentru furtunuri HD 100 până la HD 400, KP, TE
Racord 1	Filet metric de piuliță
Formă de etanșare 1	24°/60° Universal sealing head
Prescurtare	DKL
Seria	ușor
Material	Oțel
Protecția suprafeței	acoperire galvanică

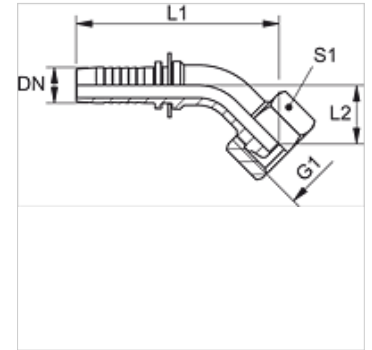

Indicație

Vă rugăm alegeți montura corespunzătoare în funcție de tipul furtunului.

Articol

Denumire	DN	Dimensiune	Țol	Presiune de lucru (bar)	G1	pentru Ø exterior țevă (mm)	L1 (mm)	L2 (mm)	S1
PN 04 AFL 45	5	3	3/16"	250,0	M 12 x 1,5	6	56,0	15,0	14
PN 06 AFL 04 45	6	4	1/4"	250,0	M 12 x 1,5	6	62,0	17,0	14
PN 06 AFL 45	6	4	1/4"	250,0	M 14 x 1,5	8	62,5	14,5	17
PN 06 AFL 08 45	6	4	1/4"	250,0	M 16 x 1,5	10	63,0	15,5	19
PN 06 AFL 10 45	6	4	1/4"	250,0	M 18 x 1,5	12	65,0	15,5	22
PN 08 AFL 45	8	5	5/16"	250,0	M 16 x 1,5	10	64,5	15,0	19
PN 08 AFL 10 45	8	5	5/16"	250,0	M 18 x 1,5	12	65,0	15,5	22
PN 10 AFL 08 45	10	6	3/8"	250,0	M 16 x 1,5	10	72,5	19,5	19
PN 10 AFL 45	10	6	3/8"	250,0	M 18 x 1,5	12	71,0	18,0	22
PN 10 AFL 13 45	10	6	3/8"	250,0	M 22 x 1,5	15	71,5	18,5	27
PN 13 AFL 45	12	8	1/2"	250,0	M 22 x 1,5	15	79,5	18,5	27
PN 13 AFL 16 45	12	8	1/2"	160,0	M 26 x 1,5	18	90,5	24,0	32
PN 16 AFL 45	16	10	5/8"	160,0	M 26 x 1,5	18	95,0	24,0	32
PN 20 AFL 45	19	12	3/4"	160,0	M 30 x 2	22	106,0	27,0	36
PN 20 AFL 25 45	19	12	3/4"	100,0	M 36 x 2	28	124,0	29,5	41
PN 25 AFL 45	25	16	1"	100,0	M 36 x 2	28	132,0	29,5	41
PN 32 AFL 45	31	20	1.1/4"	100,0	M 45 x 2	35	159,0	38,5	50
PN 40 AFL 45	38	24	1.1/2"	100,0	M 52 x 2	42	181,5	42,5	60

Variante produs

PN AFL 45 VA Niplu de sertizat, DKL 45°, oțel inoxidabil