

PN AFS

Niplu de sertizat, DKS

HANSA FLEX

Caracteristici

Domeniul de utilizare	niplu de presare pentru furtunuri HD 100 până la HD 400, KP, TE
Racord 1	Filet metric de piuliță
Formă de etanșare 1	24°/60° Universal sealing head
Prescurtare	DKS
Seria	greu
Material	Oțel
Protecția suprafeței	acoperire galvanică

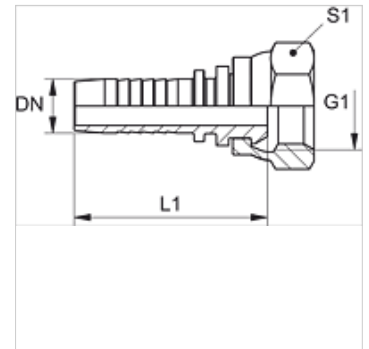

Indicație

Vă rugăm alegeți montura corespunzătoare în funcție de tipul furtunului.

Articol

Denumire	DN	Dimensiune	Țol	Presiune de lucru (bar)	G1	pentru Ø exterior țevă (mm)	L1 (mm)	S1
PN 04 AFS 03	5	3	3/16"	630,0	M 14 x 1,5	6	44,5	17
PN 04 AFS	5	3	3/16"	630,0	M 16 x 1,5	8	44,5	19
PN 06 AFS 04	6	4	1/4"	630,0	M 16 x 1,5	8	51,5	19
PN 06 AFS	6	4	1/4"	630,0	M 18 x 1,5	10	52,5	22
PN 08 AFS 06	8	5	5/16"	630,0	M 18 x 1,5	10	52,5	22
PN 08 AFS	8	5	5/16"	630,0	M 20 x 1,5	12	52,5	24
PN 10 AFS 08	10	6	3/8"	630,0	M 20 x 1,5	12	54,0	24
PN 10 AFS	10	6	3/8"	630,0	M 22 x 1,5	14	57,0	27
PN 13 AFS	12	8	1/2"	400,0	M 24 x 1,5	16	58,0	30
PN 16 AFS	16	10	5/8"	400,0	M 30 x 2	20	66,0	36
PN 20 AFS	19	12	3/4"	400,0	M 36 x 2	25	75,5	46
PN 25 AFS	25	16	1"	250,0	M 42 x 2	30	85,5	50
PN 32 AFS	31	20	1.1/4"	250,0	M 52 x 2	38	98,0	60