

PN ALI 90

Niplu de sertizat, JIS 90°

Caracteristici

Domeniul de utilizare	niplu de presare pentru furtunuri HD 100 până la HD 400, KP, TE
Racord 1	Filet metric de piuliță
Formă de etanșare 1	Con interior 60°
Standard	JIS 8363
adecvat pentru	Komatsu
Material	Oțel
Protecția suprafeței	acoperire galvanică

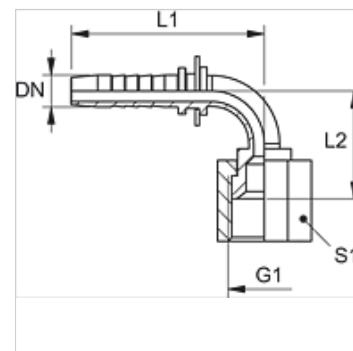

Indicație

Vă rugăm alegeți montura corespunzătoare în funcție de tipul furtunului.

Articol

Denumire	DN	Dimensiune	Țol	Presiune de lucru (bar)	G1	L1 (mm)	L2 (mm)	S1
PN 06 ALI 90	6	4	1/4"	345,0	M 14 x 1,5	63,0	31,0	17
PN 08 ALI 90	8	5	5/16"	345,0	M 16 x 1,5	70,0	42,0	19
PN 10 ALI 06 90	10	6	3/8"	345,0	M 14 x 1,5	64,0	31,0	19
PN 10 ALI 08 90	10	6	3/8"	345,0	M 16 x 1,5	72,0	42,0	22
PN 10 ALI 90	10	6	3/8"	345,0	M 18 x 1,5	73,0	42,0	22
PN 10 ALI 13 90	10	6	3/8"	345,0	M 22 x 1,5	89,0	58,0	27
PN 13 ALI 90	12	8	1/2"	345,0	M 22 x 1,5	88,0	58,0	27
PN 16 ALI 90	16	10	5/8"	275,0	M 24 x 1,5	92,0	58,0	30
PN 20 ALI 90	19	12	3/4"	275,0	M 30 x 1,5	109,0	67,0	36
PN 25 ALI 90	25	16	1"	205,0	M 33 x 1,5	118,0	70,0	41