

PN ARI

Niplu de sertizat, JIS

HANSA FLEX

Caracteristici

Domeniul de utilizare	niplu de presare pentru furtunuri HD 100 până la HD 400, KP, TE
adecvat pentru	Toyota
Racord 1	Filete BSP de piuliță
Formă de etanșare 1	Con interior 60°
Standard	JIS 8363
Material	Oțel
Protecția suprafeței	acoperire galvanică

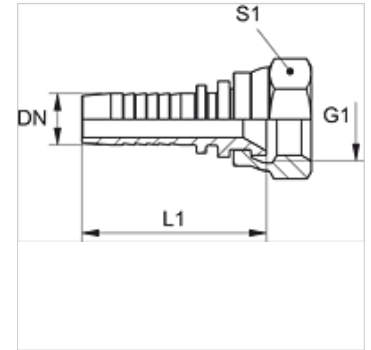

Indicație

Vă rugăm alegeți montura corespunzătoare în funcție de tipul furtunului.

Articol

Denumire	DN	Dimensiune	Țol	Presiune de lucru (bar)	G1	L1 (mm)	S1
PN 06 ARI 02	6	4	1/4"	-	G 1/8" -28	41,5	14
PN 06 ARI	6	4	1/4"	-	G 1/4" -19	42,5	19
PN 08 ARI 06	8	5	5/16"	-	G 1/4" -19	42,5	19
PN 08 ARI 10	8	5	5/16"	-	G 3/8" -19	43,0	22
PN 10 ARI	10	6	3/8"	-	G 3/8" -19	45,5	22
PN 13 ARI	12	8	1/2"	345,0	G 1/2" -14	48,0	27
PN 20 ARI	19	12	3/4"	275,0	G 3/4" -14	60,0	32
PN 25 ARI	25	16	1"	205,0	G 1" -11	71,0	38
PN 32 ARI	31	20	1.1/4"	170,0	G 1.1/4" -11	84,0	50
PN 40 ARI	38	24	1.1/2"	105,0	G 1.1/2" -11	88,5	55