

GE HRED HB

Ștuț de fixat prin înfiletare

Caracteristici

Racord 1	Filete cilindrice exterioare BSP
Formă de etanșare 1	Formă E
Racord 2	Filete cilindrice exterioare BSP
Formă de etanșare 2	Con interior 60°
Tip constructiv	Ștuț de fixat prin înfiletare
Forma constructivă	drept
Material	Oțel
Protecția suprafeței	acoperire galvanică

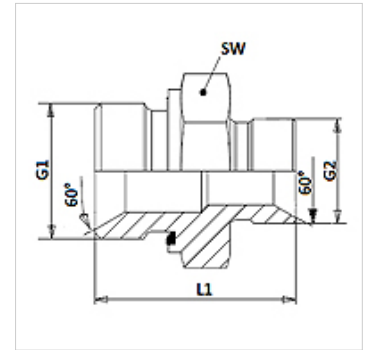

Indicație

Se poate utiliza ca dispozitiv de înfiletat cu ED și ca racord cu con interior de 60°

Articol

Denumire	G1	G2	L1 (mm)	SW (mm)
GE HRED 02 HB	G 1/8" -28	G 1/8" -28	24,0	14
GE HRED 04 HB 02	G 1/4" -19	G 1/8" -28	28,5	19
GE HRED 04 HB	G 1/4" -19	G 1/4" -19	33,0	19
GE HRED 04 HB 06	G 1/4" -19	G 3/8" -19	34,5	19
GE HRED 06 HB 04	G 3/8" -19	G 1/4" -19	33,5	22
GE HRED 06 HB	G 3/8" -19	G 3/8" -19	35,0	22
GE HRED 06 HB 08	G 3/8" -19	G 1/2" -14	38,5	22
GE HRED 08 HB 06	G 1/2" -14	G 3/8" -19	37,5	27
GE HRED 08 HB	G 1/2" -14	G 1/2" -14	41,0	27
GE HRED 08 HB 10	G 1/2" -14	G 5/8" -14	43,0	27
GE HRED 08 HB 12	G 1/2" -14	G 3/4" -14	45,0	32
GE HRED 12 HB 08	G 3/4" -14	G 1/2" -14	43,0	32
GE HRED 12 HB	G 3/4" -14	G 3/4" -14	47,0	32
GE HRED 12 HB 16	G 3/4" -14	G 1" -11	51,0	32
GE HRED 16 HB 12	G 1" -11	G 3/4" -14	49,0	41
GE HRED 16 HB	G 1" -11	G 1" -11	53,0	41
GE HRED 20 HB 16	G 1.1/4" -11	G 1" -11	55,0	50
GE HRED 20 HB	G 1.1/4" -11	G 1.1/4" -11	58,0	50
GE HRED 24 HB	G 1.1/2" -11	G 1.1/2" -11	64,0	55

SW = deschiderea cheii

Piese de schimb

WD Garnitură moale pentru racorduri filetate tip tată