

# K-WV 3/2 GEW SCHL

3/2-way valve, thread (input) - pipe (output)

## Caracteristici

Presiune de lucru	max. 10 bari
Debit 6,3 bari, p=1 bar	400 NI/min (Ø 6), 790 NI/min (Ø 8)
Racord de aer de control	4 mm
Domeniu de temperaturi	-20 °C to +60 °C
Funcția supapei	NC
Corp	Technopolymer
Piese interioare	nickel-plated brass, brass, Technopolymer, stainless steel
Material de etanșare	NBR
Montaj	Wall mounting (housing with drilled holes) Bracket mounting (mounting bracket available) Panel mounting (with bracket or lock nut)
Simbol	on the housing

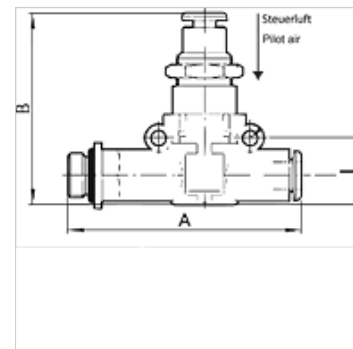
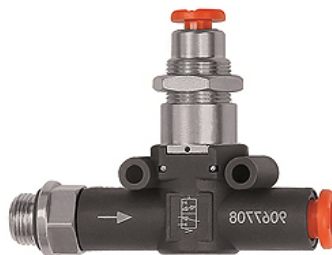

## Indicație

Alte date sunt disponibile la cerere.

## Descriere

A carefully selected assortment of products for installation in pneumatic circuits. These small, highly efficient components allow all pneumatic functions to be implemented anywhere in the circuit. The series has an ultramodular design. All components can be installed in parallel, in series, in a mixed parallel / serial configuration. Available as Pipe / pipe connection with two plug connectors Thread / pipe connection, with one plug connector and one nickel-plated brass thread.

## Articol

Denumire	Filet	pentru Ø furtun (mm)	A (mm)	B (mm)	l (mm)
K- 07 15 25 45	G 1/8	6	58,5	43,2	14,6
K- 07 15 25 46	G 1/8	8	66,2	49,7	18,7
K- 07 15 25 43	G 1/4	6	61,5	43,2	14,6
K- 07 15 25 44	G 1/4	8	70,6	49,7	18,7
K- 07 15 25 47	G 3/8	8	72,2	49,7	18,7