

К 407-1-1

Усиливающая гильза

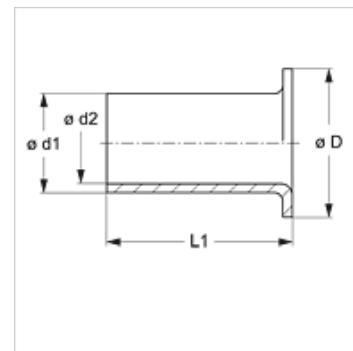

Изделие

Наименование	D (mm)	Ø d1 (mm)	Ø d2 (mm)	L1 (mm)
К 407-1-1	3,8	3	1,7	8