

K-SCHL-AUFROLLER LU WA L

Hose reels for compressed air and water, lightweight type

HANSA FLEX

Свойства

Материал шланга	PVC
Рабочее давление	max. 12 bar (K-07100622); max. 20 bar (K-07100623)
Рабочая температура	max. +60 °C
Входной патрубок	G 1/4
Угол качания	180°

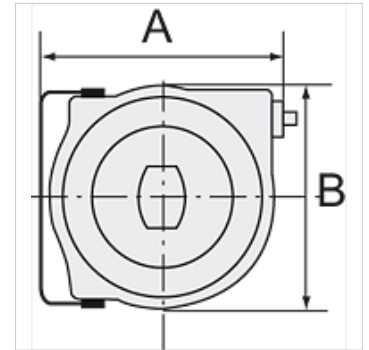

Указание

Прочие данные только по запросу.

Описание

High-quality, impact-resistant polypropylene housing. An automatic latching mechanism allows the hose to be engaged at any length. Enclosed spring. Precise locking device for continuous feeding or stop function. Reel guide prevents excessive wear on the hose.

Изделие

Наименование	Размер шланга	A (mm)	B (mm)	Длина шланга (m)
K- 07 10 06 22	12 mm x 8 mm	340,0	311,0	8
K- 07 10 06 23	12 mm x 6 mm	445,0	400,0	15