

K-VAKUUMSENSOR DIGITAL

Vacuum sensor, digital

HANSA FLEX

Свойства

Применение	Measurement of vacuum values close to the suction pad Remote evaluation of the signals Processing the output signals, for example, by PLC
Рабочие среды	dry, oil-free air and non-aggressive gases
Область температур	0 - 50 °C
Выходной сигнал	1 to 5 analogous to V
Гистерезис	Fixed: 20 mbar (model with digital sensor)
Длина кабеля	3 m
Степень защиты	IP 40

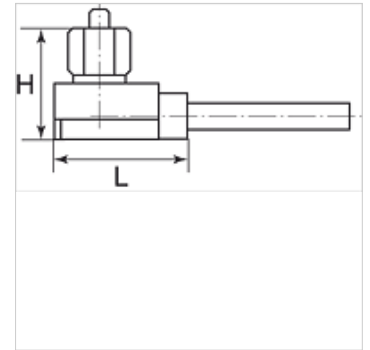

Указание

Прочие данные только по запросу.

Описание

Mini-sensor with housing and connection cable, analogue or digital output signal. Minimum size and low weight combined with high measuring accuracy.

Изделие

Наименование	Соединение	H (mm)	L (mm)	Диапазон измерений	Напряжение
K- 07 45 01 57	M 5 male	16,9	21,0	-1 bis 0 bar	10 - 24 V DC