

K-NADELVENTILE MS

Needle valves

HANSA FLEX

Свойства

Рабочее давление	Max. 16 bar
Температура	-30 °C to +110 °C
Уплотнения	NBR
Корпус	Brass
маховик	Plastic
Шпindelь	With fine adjustment

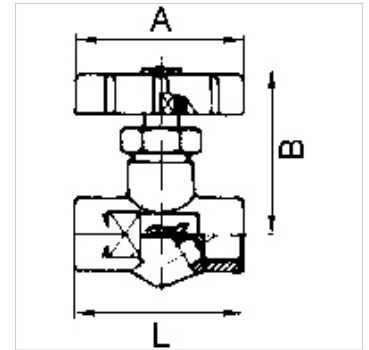
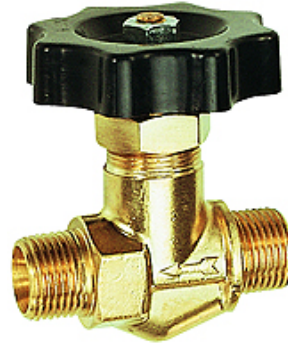

Указание

Прочие данные только по запросу.

Изделие

Наименование	DN	Резьба	A (mm)	B (mm)	L (mm)	SW (mm)
K- 07 30 03 55	4	G 1/4 male	48,0	50,0	45,0	17
K- 07 30 03 56	4	G 3/8 male	48,0	54,0	51,0	22
K- 07 30 03 57	4	G 1/4 female	48,0	48,0	42,0	17
K- 07 30 03 58	4	G 3/8 female	48,0	52,0	51,0	22
K- 07 30 03 59	4	G 1/2 female	48,0	56,0	64,0	27