

K-VTST 2 AB MS

Distributor pieces, brass, with 2 outlets

HANSA FLEX

Свойства

Соединение	G 3/4 and G 1 incl. PTFE-sealing at outer thread, G 1 1/4 without sealing
Рабочее давление	макс. 10 бар

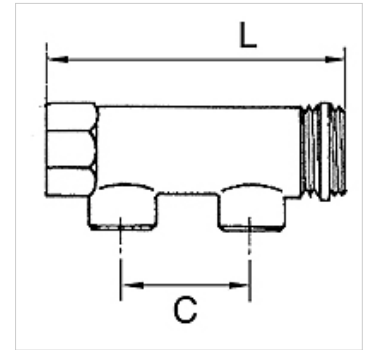

Указание

Прочие данные только по запросу.

Описание

For assembling compressed air taps. End fittings with 1 x male and 1 x female thread, outlets optionally with male or female thread.

Изделие

Наименование	Подключение выходного канала	Подключение входного канала	C (mm)	L (mm)
K- 07 40 40 49	2 x 1/2 male	2 x 3/4	50,0	110,0
K- 07 40 40 50	2 x 1/2 female	2 x 3/4	50,0	110,0
K- 07 40 40 51	2 x 1/2 male	2 x 1	50,0	113,0
K- 07 40 40 52	2 x 1/2 female	2 x 1	50,0	113,0
K- 07 40 40 53	2 x 1/2 male	2 x 1 1/4	60,0	137,0
K- 07 40 40 54	2 x 1/2 female	2 x 1 1/4	60,0	137,0