

K-PRAEZI DRUCKREGLER SELU

Precision pressure regulators

HANSA FLEX

Свойства

Входное давление	Max. 16 bar
Температура среды	max. 60 °C
Температура окружающей среды	Max. 60 °C
Рабочие среды	Micro-filtered, unooled compressed air (0.01 µm)
Соединение для манометра	G 1/4
Подключение вентиляции	G 3/8 (for mounting a silencer)
Набивочный материал	Нитрильный каучук
Корпус	Die-cast zinc
Расход собственного воздуха	1.5 - 6 l/min, depending on input pressure and control range

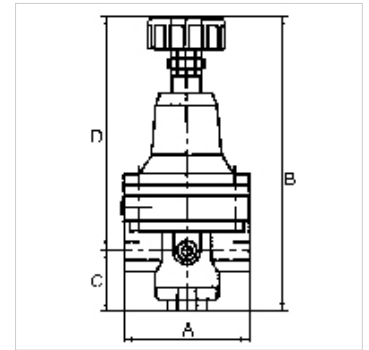

Указание

The given flow rates are based on the following parameters: 1200 l/min: P1: 5 bar, P2: 3 bar, $\Delta p \leq 0.1$ bar

1400 l/min: P1: 7 bar, P2: 5 bar, $\Delta p \leq 0.1$ bar

1500 l/min: P1: 10 bar, P2: 7 bar, $\Delta p \leq 0.1$ bar. Wear parts kit not supplied! Pressure regulator may only be opened in the factory!

Прочие данные только по запросу.

Описание

With high flow rate and large secondary relief port. Diaphragm pressure regulators with large secondary relief port for applications requiring an extremely accurate working pressure, especially at high flow rates.

Дополнительная информация

on Art. K-07250721: Max. inlet pressure 300 bar. Other cylinder pressure regulators available on request.

1500 l/min: P1: 10 bar, P2: 7 bar, $\Delta p \leq 0.1$ bar.

Изделие

Наименование	Резьба	Диапазон регулирования	Расход (L/min)	A (mm)	C (mm)	D (mm)
K- 07 25 09 28	G 1/4	0.05 - 3 bar	700	82,0	43,5	159,0
K- 07 25 09 29	G 1/4	0.05 - 7 bar	1500	82,0	43,5	159,0
K- 07 25 09 30	G 3/8	0.05 - 3 bar	3000	82,0	43,5	159,0
K- 07 25 09 31	G 3/8	0.05 - 7 bar	5500	82,0	43,5	159,0
K- 07 25 09 32	G 1/2	0.05 - 3 bar	3000	82,0	43,5	159,0
K- 07 25 09 33	G 1/2	0.05 - 5 bar	4500	82,0	43,5	159,0
K- 07 25 09 34	G 1/2	0.05 - 7 bar	5500	82,0	43,5	159,0

Запасные части

K-HALTERBAUSATZ STANDARD	Holder
K-KM MS	Hexagonal lock nuts, brass
K-SCHALLDAEPFER VYON	Vyon silencers
K-FILTERELEMENT	Filter element
K-XV AGM 2	Double nipples, parallel male thread