

K-ROHRFLANSCH DICHT INFI

Seal for pipe flange

HANSA FLEX

Свойства

Материал Нитрильный каучук
Carbon fiber

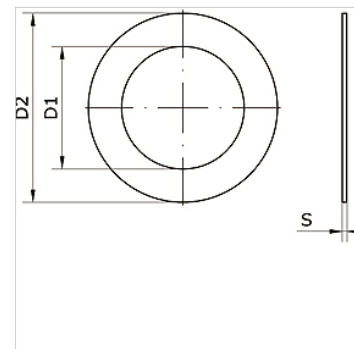

Изделие

Наименование	Для наружного Ø трубы мм	D1 (mm)	D2 (mm)	S (mm)
K- 07 40 55 12	80	89,0	131	2
K- 07 40 54 59	110	105,0	162	2