

Vlastnosti

Prípojka 1	Vonkajší závit BSP, valcový
Tvar tesnenia 1	Tvar B
Prípojka 2	metrický závit pre matice
Tvar tesnenia 2	Nátrubok so zárezným krúžkom
Konštrukcia	Nákrutka pre naskrutkovanie
Vyhotovenie	priame
Norma	DIN 2353 ISO 8434-1
Rozsah dodávky	Nátrubky s presuvnou maticou a predmontovaným zárezným krúžkom
Materiál	Ušľachtilá oceľ

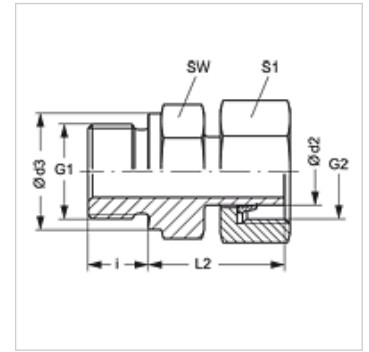

Poznámka

Pokyny pre montáž, zabudovanie, tlakové zaťaženie a povolené prevádzkové teploty nájdete v technických informáciách pre fittingové nákrutky

Výrobok

Označenie	Konštrukčný rad	Prevádzkový tlak	Ø d2 (mm)	G1	G2	Ø d3 (mm)	i (mm)	L2 (mm)	SW (mm)	S1
AVR NW 04 L VA	D	PN 315	6	G 1/8" -28	M 12 x 1,5	14	8	24,5	14	14
AVR NW 06 L VA	D	PN 315	8	G 1/4" -19	M 14 x 1,5	18	12	27,0	19	17
AVR NW 08 L VA	D	PN 315	10	G 1/4" -19	M 16 x 1,5	18	12	27,5	19	19
AVR NW 10 L 1/4 VA	D	PN 315	12	G 1/4" -19	M 18 x 1,5	18	12	28,5	19	22
AVR NW 10 L VA	D	PN 315	12	G 3/8" -19	M 18 x 1,5	22	12	30,0	22	22
AVR NW 13 L VA	D	PN 315	15	G 1/2" -14	M 22 x 1,5	26	14	30,5	27	27
AVR NW 16 L VA	D	PN 315	18	G 1/2" -14	M 26 x 1,5	26	14	31,5	27	32
AVR NW 20 L VA	D	PN 160	22	G 3/4" -14	M 30 x 2	32	16	32,5	32	36
AVR NW 25 L VA	D	PN 160	28	G 1" -11	M 36 x 2	39	18	35,0	41	41
AVR NW 32 L VA	D	PN 160	35	G 1,1/4" -11	M 45 x 2	49	20	42,5	50	50
AVR NW 40 L VA	D	PN 160	42	G 1,1/2" -11	M 52 x 2	55	22	47,0	55	60
AVR NW 03 S VA	S	PN 630	6	G 1/4" -19	M 14 x 1,5	18	12	27,0	19	17
AVR NW 04 S VA	S	PN 630	8	G 1/4" -19	M 16 x 1,5	18	12	27,0	19	19
AVR NW 06 S VA	S	PN 630	10	G 3/8" -19	M 18 x 1,5	22	12	32,0	22	22
AVR NW 08 S VA	S	PN 630	12	G 3/8" -19	M 20 x 1,5	22	12	32,0	22	24
AVR NW 10 S VA	S	PN 630	14	G 1/2" -14	M 22 x 1,5	26	14	36,5	27	27
AVR NW 13 S VA	S	PN 400	16	G 1/2" -14	M 24 x 1,5	26	14	37,0	27	30
AVR NW 13 S 3/4 VA	S	PN 400	16	G 3/4" -14	M 24 x 1,5	32	16	38,5	32	30
AVR NW 16 S VA	S	PN 400	20	G 3/4" -14	M 30 x 2	32	16	43,0	32	36
AVR NW 20 S VA	S	PN 400	25	G 1" -11	M 36 x 2	39	18	48,0	41	46
AVR NW 25 S VA	S	PN 250	30	G 1,1/4" -11	M 42 x 2	49	20	51,0	50	50
AVR NW 25 S 1 VA	S	PN 400	30	G 1" -11	M 42 x 2	39	18	50,0	41	50
AVR NW 32 S VA	S	PN 250	38	G 1,1/2" -11	M 52 x 2	55	22	60,0	55	60

Konštrukčný rad: LL = Veľmi ľahká L = Ľahká S = Ťažká - PN = Menovitý tlak PB = Max. prevádzkový tlak - Ø d2 = Vonkajší priemer rúry

Varianty produktu

AVR Nákrutka pre naskrutkovanie, Oceľ