

Vlastnosti

| | |
|--------------------------|--|
| Prípojka 1 | metrický vnútorný závit valcový |
| Tvar tesnenia 1 | Tvar A |
| Prípojka 2 | metrický vonkajší závit valcový |
| Tvar tesnenia 2 | Vnútorný kužeľ 24° |
| Konštrukcia | Nákrutka k naskrutkovaniu |
| Vyhotovenie | priame |
| Norma | DIN 2353 ISO 8434-1 |
| Rozsah dodávky | Hrdlo s presuvnou maticou a zárezným krúžkom |
| Materiál | Oceľ |
| Povrchová ochrana | galvanický povlak |

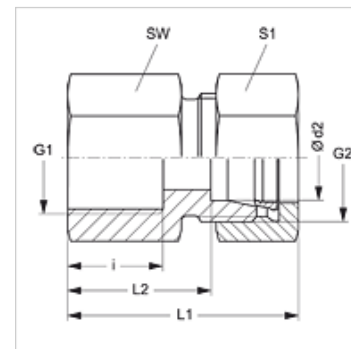

Poznámka

Pokyny pre montáž, zabudovanie, tlakové zaťaženie a povolené prevádzkové teploty nájdete v technických informáciách pre fittingové nákrutky

Výrobok

| Označenie | Konštrukčný rad | Prevádzkový tlak | Ø d2 (mm) | G1 | G2 | i (mm) | L1 (mm) | L2 (mm) | SW (mm) | S1 |
|-----------------|-----------------|------------------|-----------|------------|------------|--------|---------|---------|---------|----|
| GAM NW 04 HL | D | PN 315 | 6 | M 10 x 1 | M 12 x 1,5 | 12,5 | 34,5 | 19,5 | 14 | 14 |
| GAM NW 04 HL 22 | D | PN 315 | 6 | M 22 x 1,5 | M 12 x 1,5 | 12,0 | 35,0 | 20,0 | 27 | 14 |
| GAM NW 06 HL | D | PN 315 | 8 | M 12 x 1,5 | M 14 x 1,5 | 17,5 | 39,0 | 24,0 | 17 | 17 |
| GAM NW 06 HL 22 | D | PN 315 | 8 | M 22 x 1,5 | M 14 x 1,5 | 12,0 | 35,0 | 20,0 | 27 | 17 |
| GAM NW 08 HL | D | PN 315 | 10 | M 14 x 1,5 | M 16 x 1,5 | 17,0 | 40,0 | 25,0 | 19 | 19 |
| GAM NW 08 HL 22 | D | PN 315 | 10 | M 22 x 1,5 | M 16 x 1,5 | 12,0 | 36,0 | 21,0 | 27 | 19 |
| GAM NW 10 HL | D | PN 315 | 12 | M 16 x 1,5 | M 18 x 1,5 | 17,0 | 41,0 | 26,0 | 22 | 22 |
| GAM NW 10 HL 18 | D | PN 315 | 12 | M 18 x 1,5 | M 18 x 1,5 | 17,0 | 41,0 | 26,0 | 22 | 22 |
| GAM NW 10 HL 22 | D | PN 315 | 12 | M 22 x 1,5 | M 18 x 1,5 | 12,0 | 36,0 | 21,0 | 27 | 22 |
| GAM NW 13 HL | D | PN 315 | 15 | M 18 x 1,5 | M 22 x 1,5 | 17,0 | 42,0 | 27,0 | 24 | 27 |
| GAM NW 13 HL 22 | D | PN 315 | 15 | M 22 x 1,5 | M 22 x 1,5 | 17,0 | 42,0 | 27,0 | 24 | 27 |
| GAM NW 16 HL | D | PN 315 | 18 | M 22 x 1,5 | M 26 x 1,5 | 19,0 | 45,0 | 28,5 | 27 | 32 |
| GAM NW 20 HL | D | PN 160 | 22 | M 26 x 1,5 | M 30 x 2 | 21,0 | 50,0 | 33,5 | 32 | 36 |
| GAM NW 25 HL | D | PN 160 | 28 | M 33 x 2 | M 36 x 2 | 24,0 | 53,0 | 36,5 | 41 | 41 |
| GAM NW 32 HL | D | PN 160 | 35 | M 42 x 2 | M 45 x 2 | 26,0 | 60,0 | 38,5 | 50 | 50 |
| GAM NW 40 HL | D | PN 160 | 42 | M 48 x 2 | M 52 x 2 | 28,0 | 63,0 | 40,0 | 55 | 60 |
| GAM NW 03 HS | S | PN 400 | 6 | M 12 x 1,5 | M 14 x 1,5 | 17,0 | 41,0 | 26,0 | 17 | 17 |
| GAM NW 04 HS | S | PN 400 | 8 | M 14 x 1,5 | M 16 x 1,5 | 17,0 | 41,0 | 26,0 | 19 | 19 |
| GAM NW 06 HS | S | PN 400 | 10 | M 16 x 1,5 | M 18 x 1,5 | 17,0 | 43,0 | 26,5 | 22 | 22 |
| GAM NW 08 HS | S | PN 400 | 12 | M 18 x 1,5 | M 20 x 1,5 | 17,0 | 43,0 | 26,5 | 24 | 24 |
| GAM NW 10 HS | S | PN 400 | 14 | M 20 x 1,5 | M 22 x 1,5 | 19,0 | 49,0 | 31,0 | 27 | 27 |
| GAM NW 13 HS | S | PN 400 | 16 | M 22 x 1,5 | M 24 x 1,5 | 19,0 | 49,0 | 30,5 | 30 | 30 |
| GAM NW 16 HS | S | PN 315 | 20 | M 27 x 2 | M 30 x 2 | 22,0 | 56,0 | 34,5 | 36 | 36 |
| GAM NW 20 HS | S | PN 315 | 25 | M 33 x 2 | M 36 x 2 | 24,0 | 61,0 | 37,0 | 41 | 46 |
| GAM NW 25 HS | S | PN 315 | 30 | M 42 x 2 | M 42 x 2 | 26,0 | 68,0 | 41,5 | 55 | 60 |
| GAM NW 32 HS | S | PN 250 | 38 | M 48 x 2 | M 52 x 2 | 28,0 | 74,0 | 43,0 | 60 | 60 |

Konštrukčný rad: LL = Veľmi ľahká L = Ľahká S = Ťažká – PN = Menovitý tlak PB = Max. prevádzkový tlak – Ø d2 = Vonkajší priemer rúry

Varianty produktu

| | |
|---------------|--|
| GAM VA | Nákrutka pre naskrutkovanie, Ušľachtilá oceľ |
| XGAM | Nákrutka pre naskrutkovanie, Oceľ |