

Vlastnosti

Prípojka 1	Vnútorý závit NPT
Tvar tesnenia 1	tesniaci závit
Prípojka 2	metrický vonkajší závit valcový
Tvar tesnenia 2	Vnútorý kužeľ 24°
Konštrukcia	Nákrutka k naskrutkovaniu
Vyhotovenie	priame
Rozsah dodávky	Hrdlo s presuvnou maticou a zárezným krúžkom
Materiál	Ušľachtilá oceľ

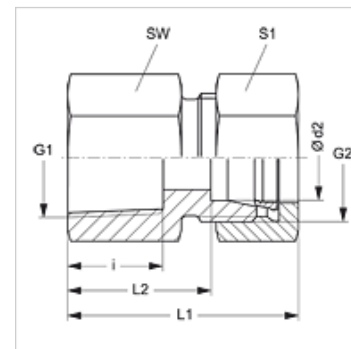

Poznámka

Pokyny pre montáž, zabudovanie, tlakové zaťaženie a povolené prevádzkové teploty nájdete v technických informáciách pre fittingové nákrutky

Výrobok

Označenie	Konštrukčný rad	Prevádzkový tlak	Ø d2 (mm)	G1	G2	i (mm)	L1 (mm)	L2 (mm)	SW (mm)	S1
GAN NW 04 HL VA	D	PN 315	6	1/8" -27 NPT	M 12 x 1,5	11,6	34,0	19,0	14	14
GAN NW 04 HL 1/4 VA	D	PN 315	6	1/4" -18 NPT	M 12 x 1,5	16,4	38,0	23,5	19	14
GAN NW 06 HL VA	D	PN 315	8	1/4" -18 NPT	M 14 x 1,5	16,4	38,0	23,5	19	17
GAN NW 08 HL VA	D	PN 315	10	1/4" -18 NPT	M 16 x 1,5	16,4	39,0	24,0	19	19
GAN NW 08 HL 1/2 VA	D	PN 315	10	1/2" -14 NPT	M 16 x 1,5	22,6	38,0	26,0	27	19
GAN NW 10 HL 1/4 VA	D	PN 315	12	1/4" -18 NPT	M 18 x 1,5	16,4	43,0	23,5	19	19
GAN NW 10 HL VA	D	PN 315	12	3/8" -18 NPT	M 18 x 1,5	17,4	42,0	27,0	24	22
GAN NW 10 HL 1/2 VA	D	PN 315	12	1/2" -14 NPT	M 18 x 1,5	22,6	47,0	32,0	27	22
GAN NW 13 HL VA	D	PN 315	15	1/2" -14 NPT	M 22 x 1,5	22,6	48,0	33,0	27	27
GAN NW 16 HL VA	D	PN 315	18	1/2" -14 NPT	M 26 x 1,5	22,6	49,0	32,5	27	32
GAN NW 20 HL VA	D	PN 160	22	3/4" -14 NPT	M 30 x 2	23,1	52,0	35,5	36	36
GAN NW 25 HL VA	D	PN 160	28	1" -11,5 NPT	M 36 x 2	27,8	57,0	40,5	41	41
GAN NW 32 HL VA	D	PN 160	35	1,1/4" -11,5 NPT	M 45 x 2	28,3	62,0	40,5	55	50
GAN NW 40 HL VA	D	PN 160	42	1,1/2" -11,5 NPT	M 52 x 2	28,3	65,0	42,0	60	60
GAN NW 03 HS VA	S	PN 630	6	1/4" -18 NPT	M 14 x 1,5	16,4	41,0	26,0	19	17
GAN NW 04 HS VA	S	PN 630	8	1/4" -18 NPT	M 16 x 1,5	16,4	41,0	26,0	19	19
GAN NW 06 HS VA	S	PN 630	10	3/8" -18 NPT	M 18 x 1,5	17,4	44,0	27,0	24	22
GAN NW 08 HS VA	S	PN 630	12	3/8" -18 NPT	M 20 x 1,5	17,4	44,0	27,5	24	24
GAN NW 08 HS 1/2 VA	S	PN 630	12	1/2" -14 NPT	M 20 x 1,5	22,6	50,0	33,5	27	24
GAN NW 10 HS VA	S	PN 630	14	1/2" -14 NPT	M 22 x 1,5	22,6	53,0	35,0	27	27
GAN NW 13 HS VA	S	PN 400	16	1/2" -14 NPT	M 24 x 1,5	22,6	50,0	34,5	27	30
GAN NW 16 HS VA	S	PN 400	20	3/4" -14 NPT	M 30 x 2	23,1	57,0	35,5	32	36
GAN NW 20 HS VA	S	PN 400	25	1" -11,5 NPT	M 36 x 2	27,8	65,0	41,0	41	46
GAN NW 25 HS VA	S	PN 400	30	1,1/4" -11,5 NPT	M 42 x 2	28,3	70,0	43,5	55	50
GAN NW 32 HS VA	S	PN 315	38	1,1/2" -11,5 NPT	M 52 x 2	28,3	74,0	43,0	60	60

Konštrukčný rad: LL = Veľmi ľahká L = Ľahká S = Ťažká - PN = Menovitý tlak PB = Max. prevádzkový tlak - Ø d2 = Vonkajší priemer rúry

Varianty produktu

XGAN VA Nákrutka pre naskrutkovanie, Hrdlo (bez presuvnej matice a zárezného krúžku)