

Vlastnosti

Prípojka 1	Vnútorný závit BSP, valcový
Tvar tesnenia 1	Tvar A
Prípojka 2	metrický vonkajší závit valcový
Tvar tesnenia 2	Vnútorný kužeľ 24°
Konštrukcia	Nákrutka k naskrutkovaniu
Vyhotovenie	priame
Norma	DIN 2353 ISO 8434-1
Rozsah dodávky	Hrdlo s presuvnou maticou a zárezným krúžkom
Materiál	Oceľ
Povrchová ochrana	galvanický povlak

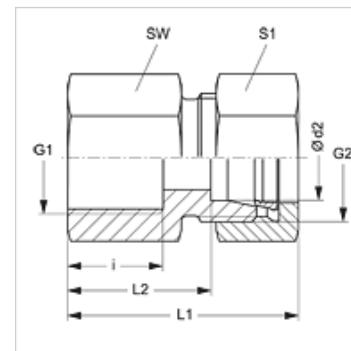

Poznámka

Pokyny pre montáž, zabudovanie, tlakové zaťaženie a povolené prevádzkové teploty nájdete v technických informáciách pre fittingové nákrutky

Výrobok

Označenie	Konštrukčný rad	Prevádzkový tlak	Ø d2 (mm)	G1	G2	i (mm)	L1 (mm)	L2 (mm)	SW (mm)	S1
GAR NW 04 HL	D	PN 315	6	G 1/8" -28	M 12 x 1,5	12,0	34,0	19,0	14	14
GAR NW 04 HL 1/4	D	PN 315	6	G 1/4" -19	M 12 x 1,5	12,0	34,0	19,0	14	14
GAR NW 04 HL 3/8	D	PN 315	6	G 3/8" -19	M 12 x 1,5	12,0	36,0	21,0	22	14
GAR NW 06 HL	D	PN 315	8	G 1/4" -19	M 14 x 1,5	17,0	39,0	24,0	19	17
GAR NW 06 HL 3/8	D	PN 315	8	G 3/8" -19	M 14 x 1,5	17,0	36,0	21,0	22	17
GAR NW 06 HL 1/2	D	PN 315	8	G 1/2" -14	M 14 x 1,5	20,0	44,0	29,0	27	17
GAR NW 08 HL	D	PN 315	10	G 1/4" -19	M 16 x 1,5	17,0	40,0	25,0	19	19
GAR NW 08 HL 3/8	D	PN 315	10	G 3/8" -19	M 16 x 1,5	17,0	40,0	26,0	22	19
GAR NW 08 HL 1/2	D	PN 315	10	G 1/2" -14	M 16 x 1,5	20,0	45,0	30,0	27	19
GAR NW 10 HL 1/4	D	PN 315	12	G 1/4" -19	M 18 x 1,5	17,0	41,0	25,0	19	22
GAR NW 10 HL	D	PN 315	12	G 3/8" -19	M 18 x 1,5	17,0	41,0	26,0	22	22
GAR NW 10 HL 1/2	D	PN 315	12	G 1/2" -14	M 18 x 1,5	20,0	44,0	30,0	27	22
GAR NW 13 HL 3/8	D	PN 315	15	G 3/8" -19	M 22 x 1,5	17,0	46,0	27,0	24	27
GAR NW 13 HL	D	PN 315	15	G 1/2" -14	M 22 x 1,5	20,0	45,0	30,0	27	27
GAR NW 16 HL	D	PN 315	18	G 1/2" -14	M 26 x 1,5	20,0	46,0	29,5	27	32
GAR NW 20 HL	D	PN 160	22	G 3/4" -14	M 30 x 2	22,0	51,0	34,5	32	36
GAR NW 25 HL	D	PN 160	28	G 1" -11	M 36 x 2	24,5	53,5	37,0	41	41
GAR NW 32 HL	D	PN 160	35	G 1,1/4" -11	M 45 x 2	26,5	60,5	39,0	50	50
GAR NW 40 HL	D	PN 160	42	G 1,1/2" -11	M 52 x 2	28,5	63,5	40,5	55	60
GAR NW 03 HS	S	PN 400	6	G 1/4" -19	M 14 x 1,5	17,0	41,0	26,0	19	17
GAR NW 04 HS	S	PN 400	8	G 1/4" -19	M 16 x 1,5	17,0	41,0	26,0	19	19
GAR NW 06 HS	S	PN 400	10	G 3/8" -19	M 18 x 1,5	17,0	42,0	26,5	24	22
GAR NW 08 HS	S	PN 400	12	G 3/8" -19	M 20 x 1,5	17,0	42,0	26,5	24	24
GAR NW 10 HS	S	PN 400	14	G 1/2" -14	M 22 x 1,5	20,0	50,0	32,0	27	27
GAR NW 13 HS	S	PN 400	16	G 1/2" -14	M 24 x 1,5	20,0	50,0	31,5	27	30
GAR NW 16 HS	S	PN 315	20	G 3/4" -14	M 30 x 2	22,0	56,0	34,5	36	36
GAR NW 20 HS	S	PN 315	25	G 1" -11	M 36 x 2	24,5	61,5	37,5	41	46
GAR NW 25 HS	S	PN 315	30	G 1,1/4" -11	M 42 x 2	26,5	68,5	42,0	50	50
GAR NW 32 HS	S	PN 250	38	G 1,1/2" -11	M 52 x 2	28,5	74,5	43,5	60	60

Konštrukčný rad: LL = Veľmi ľahká L = Ľahká S = Ťažká - PN = Menovitý tlak PB = Max. prevádzkový tlak - Ø d2 = Vonkajší priemer rúry

Varianty produktu

GAR MG	Nákrutka pre naskrutkovanie, Mosadz
GAR VA	Nákrutka pre naskrutkovanie, Ušľachtilá oceľ
XGAR	Nákrutka pre naskrutkovanie, Oceľ