

### Vlastnosti

<b>Prípojka 1</b>	Vonkajší závit BSP, valcový
<b>Tvar tesnenia 1</b>	Tvar E
<b>Prípojka 2</b>	metrický vonkajší závit valcový
<b>Tvar tesnenia 2</b>	Vnútorný kužeľ 24°
<b>Konštrukcia</b>	Otočná nákrutka (skrutkované pripojenie)
<b>Konštrukcia, doplnok</b>	Klzné ložisko
<b>Vyhotovenie</b>	priame
<b>Rozsah dodávky</b>	Hrdlo (bez presuvnej matice a zárezného krúžku)
<b>Materiál</b>	Oceľ
<b>Povrchová ochrana</b>	galvanický povlak

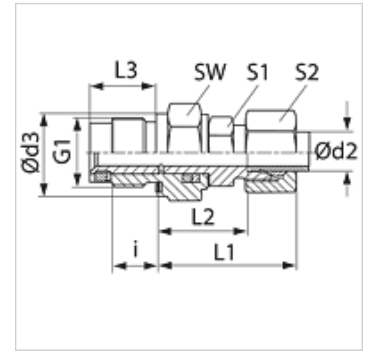

### Poznámka

Pokyny pre montáž, zabudovanie, tlakové zaťaženie a povolené prevádzkové teploty nájdete v technických informáciách pre fittingové nákrutky

### Výrobok

Označenie	Konštrukčný rad	Prevádzkový tlak	Ø d2 (mm)	G1	i (mm)	Ø d3 (mm)	L1 (mm)	L2 (mm)	L3 (mm)	SW (mm)	S1	S2
GVR NW 04 HL 1/4	D	PN 40	6	G 1/4" -19	12	19	40	21,0	18,0	19	12	14
GVR NW 06 HL	D	PN 40	8	G 1/4" -19	12	19	40	21,0	18,0	19	14	17
GVR NW 08 HL 3/8	D	PN 40	10	G 3/8" -19	12	22	40	25,0	18,0	24	17	19
GVR NW 10 HL 1/2	D	PN 40	12	G 1/2" -14	14	27	42	27,0	21,0	27	19	22
GVR NW 13 HL 3/4	D	PN 40	15	G 3/4" -14	16	32	47	32,0	24,0	32	24	27
GVR NW 16 HL 1	D	PN 40	18	G 1" -11	18	40	51	35,0	27,5	41	27	22
GVR NW 20 HL 1	D	PN 40	22	G 1" -11	18	40	55	39,5	27,5	41	32	36
GVR NW 25 HL 1 1/4	D	PN 40	28	G 1,1/4" -11	20	40	57	40,5	31,0	50	41	41
GVR NW 32 HL 1 1/2	D	PN 40	35	G 1,1/2" -11	22	55	66	44,5	35,0	55	46	50
GVR NW 03 HS	S	PN 100	6	G 1/4" -19	12	19	38	23,0	18,0	19	14	17
GVR NW 04 HS	S	PN 100	8	G 1/4" -19	12	19	39	24,0	18,0	19	17	19
GVR NW 06 HS	S	PN 100	10	G 3/8" -19	12	22	43	26,5	18,0	24	19	22
GVR NW 08 HS 1/2	S	PN 100	12	G 1/2" -14	14	27	45	28,5	21,0	27	22	24
GVR NW 13 HS 3/4	S	PN 100	16	G 3/4" -14	16	32	52	33,5	24,0	32	27	30
GVR NW 16 HS 1	S	PN 100	20	G 1" -11	18	40	60	38,0	27,5	41	32	36
GVR NW 20 HS	S	PN 100	25	G 1" -11	18	40	65	40,5	27,5	41	41	46
GVR NW 25 HS 1 1/4	S	PN 100	30	G 1,1/4" -11	20	50	68	41,5	31,0	50	46	50
GVR NW 32 HS 1 1/2	S	PN 100	38	G 1,1/2" -11	22	55	78	47,0	35,0	55	55	60

Konštrukčný rad: LL = Veľmi ľahká L = Ľahká S = Ťažká - PN = Menovitý tlak PB = Max. prevádzkový tlak - Ø d2 = Vonkajší priemer rúry