

Vlastnosti

Prípojka 1	Vonkajší závit NPT
Tvar tesnenia 1	tesniaci závit
Prípojka 2 + 3	metrický vonkajší závit valcový
Tvar tesnenia 2 + 3	Vnútný kužeľ 24°
Konštrukcia	Nákrutka pre naskrutkovanie
Vyhotovenie	Tvar T
Norma	DIN 3865
Rozsah dodávky	Hrdlo s presuvnou maticou a zárezným krúžkom
Materiál	Oceľ
Povrchová ochrana	galvanický povlak

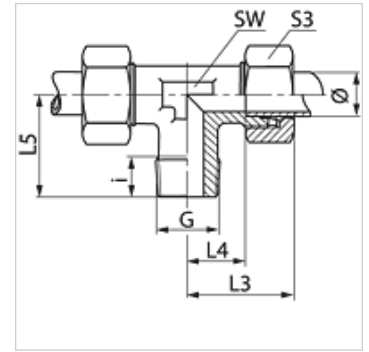

Poznámka

Pokyny pre montáž, zabudovanie, tlakové zaťaženie a povolené prevádzkové teploty nájdete v technických informáciách pre fittingové nákrutky

Výrobok

Označenie	Konštrukčný rad	Prevádzkový tlak	Rúrka, vonkajší Ø (mm)	G	i (mm)	L3 (mm)	L4 (mm)	L5 (mm)	SW (mm)	S3
TN 04 LL	LL	PN 100	4	1/8" -27 NPT	8	21	11,0	17	9	10
TN 05 LL	LL	PN 100	5	1/8" -27 NPT	8	21	9,5	17	9	12
TN 06 LL	LL	PN 100	6	1/8" -27 NPT	8	21	9,5	17	9	12
TN 08 LL	LL	PN 100	8	1/8" -27 NPT	8	23	11,5	20	12	14
TN NW 04 HL	D	PN 315	6	1/8" -27 NPT	8	27	12,0	20	12	14
TN NW 04 HL 1/4	D	PN 315	6	1/4" -18 NPT	10	27	12,0	20	12	14
TN NW 06 HL	D	PN 315	8	1/4" -18 NPT	12	29	14,0	26	12	17
TN NW 08 HL	D	PN 315	10	1/4" -18 NPT	12	30	15,0	27	14	19
TN NW 10 HL	D	PN 315	12	3/8" -18 NPT	12	32	17,0	28	17	22
TN NW 13 HL	D	PN 315	15	1/2" -14 NPT	14	36	21,0	34	19	27
TN NW 16 HL	D	PN 315	18	1/2" -14 NPT	14	40	23,5	36	24	32
TN NW 20 HL	D	PN 160	22	3/4" -14 NPT	16	44	27,5	42	27	36
TN NW 25 HL	D	PN 160	28	1" -11,5 NPT	16	47	30,5	48	36	41
TN NW 32 HL	D	PN 160	35	1,1/4" -11,5 NPT	20	56	34,5	54	41	50
TN NW 40 HL	D	PN 160	42	1,1/2" -11,5 NPT	22	63	40,0	61	50	60
TN NW 03 HS	S	PN 630	6	1/4" -18 NPT	12	31	16,0	26	12	17
TN NW 04 HS	S	PN 630	8	1/4" -18 NPT	12	32	17,0	27	14	19
TN NW 06 HS	S	PN 630	10	3/8" -18 NPT	12	34	17,5	28	17	22
TN NW 08 HS	S	PN 630	12	3/8" -18 NPT	12	38	21,5	28	17	24
TN NW 10 HS	S	PN 630	14	1/2" -14 NPT	14	40	22,0	32	19	27
TN NW 13 HS	S	PN 400	16	1/2" -14 NPT	14	43	24,5	32	24	30
TN NW 16 HS	S	PN 400	20	3/4" -14 NPT	16	48	26,5	42	27	36
TN NW 20 HS	S	PN 400	25	1" -11,5 NPT	18	54	30,0	48	36	46
TN NW 25 HS	S	PN 400	30	1,1/4" -11,5 NPT	20	62	35,5	54	41	50
TN NW 32 HS	S	PN 315	38	1,1/2" -11,5 NPT	22	72	41,0	61	50	60

Konštrukčný rad: LL = Veľmi ľahká L = Ľahká S = Ťažká - PN = Menovitý tlak PB = Max. prevádzkový tlak - Ø = Vonkajší priemer rúrky

Varianty produktu

TN VA	Nákrutka k naskrutkovaniu, tvar T, Ušľachtilá oceľ
XTN	Nákrutka k naskrutkovaniu, tvar T, Oceľ