

Vlastnosti

Prípojka 1	Vonkajší závit BSP, valcový
Tvar tesnenia 1	Tvar B
Prípojka 2	Nátrubky nepredmontované
Tvar tesnenia 2	Pripojenie so zárezným krúžkom
Konštrukcia	Hrdlo k zaskrutkovaniu
Vyhotovenie	priame
Norma	DIN 2353 ISO 8434-1
Rozsah dodávky	Hrdlo (bez presuvnej matice a zárezného krúžku)
Materiál	Oceľ
Povrchová ochrana	galvanický povlak

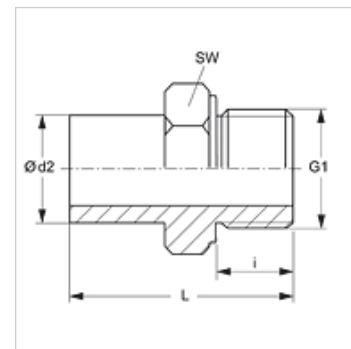

Poznámka

Pokyny pre montáž, zabudovanie, tlakové zaťaženie a povolené prevádzkové teploty nájdete v technických informáciách pre fittingové nákrutky

Výrobok

Označenie	Konštrukčný rad	Prevádzkový tlak	Ø d2 (mm)	G1	i (mm)	D (mm)	SW (mm)
NVR NW 04 L	D	PN 315	6	G 1/8" -28	8	32,5	14
NVR NW 06 L	D	PN 315	8	G 1/4" -19	12	39,0	19
NVR NW 08 L	D	PN 315	10	G 1/4" -19	12	39,5	19
NVR NW 10 L 1/4	D	PN 250	12	G 1/4" -19	12	40,5	19
NVR NW 10 L	D	PN 315	12	G 3/8" -19	12	42,0	22
NVR NW 10 L 1/2	D	PN 250	12	G 1/2" -14	14	44,5	27
NVR NW 13 L 3/8	D	PN 250	15	G 3/8" -19	12	42,0	22
NVR NW 13 L	D	PN 315	15	G 1/2" -14	14	44,5	27
NVR NW 16 L	D	PN 315	18	G 1/2" -14	14	45,5	27
NVR NW 20 L 1/2	D	PN 160	22	G 1/2" -14	14	46,0	27
NVR NW 20 L	D	PN 160	22	G 3/4" -14	16	48,5	32
NVR NW 25 L	D	PN 160	28	G 1" -11	18	53,0	41
NVR NW 32 L	D	PN 160	35	G 1,1/4" -11	20	62,5	50
NVR NW 40 L	D	PN 160	42	G 1,1/2" -11	22	69,0	55
NVR NW 03 S	S	PN 400	6	G 1/4" -19	12	39,0	19
NVR NW 04 S	S	PN 400	8	G 1/4" -19	12	39,0	19
NVR NW 06 S	S	PN 400	10	G 3/8" -19	12	44,0	22
NVR NW 08 S	S	PN 400	12	G 3/8" -19	12	44,0	22
NVR NW 08 S 1/2	S	PN 400	12	G 1/2" -14	14	49,0	27
NVR NW 10 S	S	PN 400	14	G 1/2" -14	14	50,5	27
NVR NW 13 S 3/8	S	PN 400	16	G 3/8" -19	12	46,0	22
NVR NW 13 S	S	PN 400	16	G 1/2" -14	14	51,0	27
NVR NW 13 S 3/4	S	PN 400	16	G 3/4" -14	16	54,5	32
NVR NW 16 S 1/2	S	PN 400	20	G 1/2" -14	14	55,5	27
NVR NW 16 S	S	PN 400	20	G 3/4" -14	16	59,0	32
NVR NW 20 S	S	PN 250	25	G 1" -11	18	66,0	41
NVR NW 25 S	S	PN 160	30	G 1,1/4" -11	20	71,0	50
NVR NW 32 S	S	PN 160	38	G 1,1/2" -11	22	82,0	55

Konštrukčný rad: LL = Veľmi ľahká L = Ľahká S = Ťažká - PN = Menovitý tlak PB = Max. prevádzkový tlak - Ø d2 = Vonkajší priemer rúry

Varianty produktu

NVR VA Hrdlo k naskrutkovaniu, Ušľachtilá oceľ

Prídavné elementy

VOM Predmontované hrdlá