

Vlastnosti

Prípojka 1	Vonkajší závit BSP, valcový
Tvar tesnenia 1	Tvar E
Prípojka 2	Nátrubky nepredmontované
Tvar tesnenia 2	Pripojenie so zárezným krúžkom
Konštrukcia	Hrdlo k zaskrutkovaniu
Vyhotovenie	priame
Norma	DIN 2353 ISO 8434-1
Rozsah dodávky	Hrdlo (bez presuvnej matice a zárezného krúžku)
Materiál	Ušľachtilá oceľ

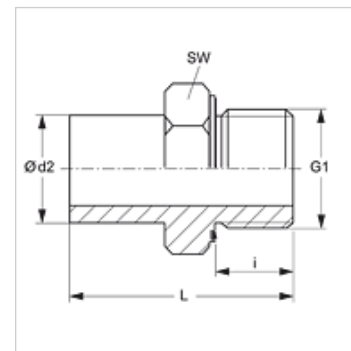

Poznámka

Pokyny pre montáž, zabudovanie, tlakové zaťaženie a povolené prevádzkové teploty nájdete v technických informáciách pre fittingové nákrutky

Pokyny pre objednanie

NBR tesnenie

FPM (Viton) na vyžiadanie

Výrobok

Označenie	Konštrukčný rad	Prevádzkový tlak	Ø d2 (mm)	G1	i (mm)	D (mm)	SW (mm)
NVR NW 04 L ED VA	D	PN 315	6	G 1/8" -28	8	32,5	14
NVR NW 04 L 1/4 ED VA	D	PN 315	6	G 1/4" -19	12	38,5	19
NVR NW 06 L ED VA	D	PN 315	8	G 1/4" -19	12	39,0	19
NVR NW 08 L ED VA	D	PN 315	10	G 1/4" -19	12	39,5	19
NVR NW 08 L 3/8 ED VA	D	PN 315	10	G 3/8" -19	12	41,0	22
NVR NW 08 L 1/2 ED VA	D	PN 315	10	G 1/2" -14	14	43,5	27
NVR NW 10 L 1/4 ED VA	D	PN 315	12	G 1/4" -19	12	40,5	19
NVR NW 10 L ED VA	D	PN 315	12	G 3/8" -19	12	42,0	22
NVR NW 10 L 1/2 ED VA	D	PN 315	12	G 1/2" -14	14	44,5	27
NVR NW 13 L 3/8 ED VA	D	PN 315	15	G 3/8" -19	12	42,0	22
NVR NW 13 L ED VA	D	PN 315	15	G 1/2" -14	14	44,5	27
NVR NW 16 L 3/8 ED VA	D	PN 315	18	G 3/8" -19	12	43,0	22
NVR NW 16 L ED VA	D	PN 315	18	G 1/2" -14	14	45,5	27
NVR NW 16 L 3/4 ED VA	D	PN 315	18	G 3/4" -14	16	48,0	32
NVR NW 20 L 3/8 ED VA	D	PN 160	22	G 3/8" -19	12	43,5	27
NVR NW 20 L 1/2 ED VA	D	PN 160	22	G 1/2" -14	14	46,0	27
NVR NW 20 L ED VA	D	PN 160	22	G 3/4" -14	16	48,5	32
NVR NW 25 L ED VA	D	PN 160	28	G 1" -11	18	53,0	41
NVR NW 32 L ED VA	D	PN 160	35	G 1,1/4" -11	20	62,5	50
NVR NW 40 L ED VA	D	PN 160	42	G 1,1/2" -11	22	69,0	55
NVR NW 03 S 1/8 ED VA	S	PN 630	6	G 1/8" -28	8	34,5	14
NVR NW 03 S ED VA	S	PN 630	6	G 1/4" -19	12	39,0	19
NVR NW 04 S ED VA	S	PN 630	8	G 1/4" -19	12	39,0	19
NVR NW 06 S 1/4 ED VA	S	PN 630	10	G 1/4" -19	12	42,0	19
NVR NW 06 S ED VA	S	PN 630	10	G 3/8" -19	12	44,0	22
NVR NW 06 S 1/2 ED VA	S	PN 630	10	G 1/2" -14	14	49,0	27
NVR NW 08 S 1/4 ED VA	S	PN 630	12	G 1/4" -19	12	42,0	19
NVR NW 08 S ED VA	S	PN 630	12	G 3/8" -19	12	44,0	22
NVR NW 08 S 1/2 ED VA	S	PN 630	12	G 1/2" -14	14	49,0	27
NVR NW 10 S 1/4 ED VA	S	PN 630	14	G 1/4" -19	12	43,5	19
NVR NW 10 S ED VA	S	PN 630	14	G 1/2" -14	14	50,5	27
NVR NW 13 S 3/8 ED VA	S	PN 400	16	G 3/8" -19	12	46,0	22
NVR NW 13 S ED VA	S	PN 400	16	G 1/2" -14	14	51,0	27
NVR NW 13 S 3/4 ED VA	S	PN 400	16	G 3/4" -14	16	54,5	32
NVR NW 16 S 1/2 ED VA	S	PN 400	20	G 1/2" -14	14	55,5	27
NVR NW 16 S ED VA	S	PN 400	20	G 3/4" -14	16	59,0	32
NVR NW 20 S 3/4 ED VA	S	PN 400	25	G 3/4" -14	16	62,0	32



Výrobok

Označenie	Konstrukčný rad	Prevádzkový tlak	Ø d2 (mm)	G1	i (mm)	D (mm)	SW (mm)
NVR NW 20 S ED VA	S	PN 400	25	G 1" -11	18	66,0	41
NVR NW 25 S ED VA	S	PN 400	30	G 1,1/4" -11	20	71,0	50
NVR NW 32 S ED VA	S	PN 315	38	G 1,1/2" -11	22	82,0	55

Konstrukčný rad: LL = Veľmi ľahká L = Ľahká S = Ťažká – PN = Menovitý tlak PB = Max. prevádzkový tlak – Ø d2 = Vonkajší priemer rúry

Variety produktu

NVR ED Hrdlo k naskrutkovaniu, Oceľ

Náhradné diely

WD V Mäkké tesnenie JIC

Prídavné elementy

VOM Predmontované hrdlá