

Vlastnosti

Prípojka 1	Vonkajší závit BSP, valcový
Tvar tesnenia 1	Krúžok s tesniacou hranou
Prípojka 2 + 3	metrický vonkajší závit valcový
Tvar tesnenia 2 + 3	Vnútny kužeľ 24°
Konštrukcia	Otočná nákrutka bez škrtenia
Vyhotovenie	Tvar T
Norma	ISO 8434-1
Rozsah dodávky	Hrdlo (bez presuvnej matice a zárezného krúžku)
Materiál	Oceľ
Povrchová ochrana	galvanický povlak

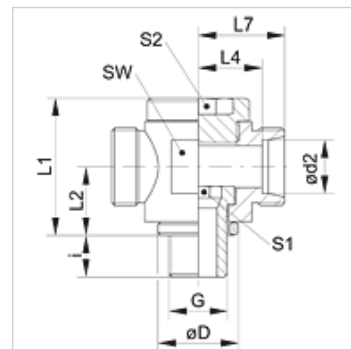

Poznámka

Pokyny pre montáž, zabudovanie, tlakové zaťaženie a povolené prevádzkové teploty nájdete v technických informáciách pre fittingové nákrutky

Výrobok

Označenie	Konštrukčný rad	Prevádzkový tlak	Ø d2 (mm)	G	Ø D (mm)	i (mm)	L1 (mm)	L2 (mm)	L4 (mm)	L7 (mm)	SW (mm)	S1	S2
XDTR NW 04 HL	D	PN 160	6	G 1/8" -28	14,0	8	24	12	12,0	19	19	6	6
XDTR NW 06 HL	D	PN 160	8	G 1/4" -19	18,0	12	30	15	14,0	21	22	8	8
XDTR NW 08 HL	D	PN 100	10	G 1/4" -19	18,0	12	30	15	15,0	22	22	8	8
XDTR NW 10 HL	D	PN 100	12	G 3/8" -19	22,0	12	36	18	17,5	24	27	10	10
XDTR NW 13 HL	D	PN 100	15	G 1/2" -14	26,0	14	40	20	20,0	27	30	12	12
XDTR NW 16 HL	D	PN 100	18	G 1/2" -14	26,0	14	40	20	19,5	27	30	12	12
XDTR NW 20 HL	D	PN 100	22	G 3/4" -14	32,0	16	52	25	27,0	34	41	17	17
XDTR NW 25 HL	D	PN 100	28	G 1" -11	39,0	18	58	29	29,5	37	46	22	22
XDTR NW 32 HL	D	PN 63	35	G 1,1/4" -11	49,0	20	69	34	33,0	44	55	27	27
XDTR NW 40 HL	D	PN 63	42	G 1,1/2" -11	55,0	22	84	41	40,0	51	70	32	32
XDTR NW 03 HS	S	PN 160	6	G 1/4" -19	18,0	12	30	15	16,0	23	22	8	8
XDTR NW 04 HS	S	PN 160	8	G 1/4" -19	18,0	12	30	15	16,0	23	22	8	8
XDTR NW 06 HS	S	PN 100	10	G 3/8" -19	22,0	12	36	18	18,0	25	27	10	10
XDTR NW 08 HS	S	PN 100	12	G 3/8" -19	22,0	12	36	18	24,0	25	27	10	10
XDTR NW 10 HS	S	PN 100	14	G 1/2" -14	26,0	14	42	21	22,0	30	32	12	12
XDTR NW 13 HS	S	PN 100	16	G 1/2" -14	26,0	14	42	21	21,5	30	32	12	12
XDTR NW 16 HS	S	PN 100	20	G 3/4" -14	32,0	16	57	28	28,5	39	46	17	17
XDTR NW 20 HS	S	PN 100	25	G 1" -11	39,0	18	62	31	31,0	43	50	22	22
XDTR NW 25 HS	S	PN 63	30	G 1,1/4" -11	49,0	20	74	36	36,5	50	60	27	27
XDTR NW 32 HS	S	PN 63	38	G 1,1/2" -11	55,0	22	84	41	41,0	57	70	32	32

Konštrukčný rad: LL = Veľmi ľahká L = Ľahká S = Ťažká - PN = Menovitý tlak PB = Max. prevádzkový tlak - Ø d2 = Vonkajší priemer rúry

Varianty produktu

XDTR VA	Otočná nákrutka, bez škrtenia, tvar T, Hrdlo (bez presuvnej matice a zárezného krúžku)
DTR	Otočná nákrutka, bez škrtenia, tvar T, Hrdlo s presuvnou maticou a zárezným krúžkom