

Vlastnosti

Prípojka 1	Vonkajší závit BSP, valcový
Tvar tesnenia 1	Tvar G
Prípojka 2 + 3	metrický vonkajší závit valcový
Tvar tesnenia 2 + 3	Vnútny kužeľ 24°
Konštrukcia	Nákrutka pre naskrutkovanie s nastaviteľným smerom
Vyhotovenie	Tvar T
Norma	ISO 8434-1
Rozsah dodávky	Hrdlo (bez presuvnej matice a zárezného krúžku)
Materiál	Oceľ
Povrchová ochrana	galvanický povlak

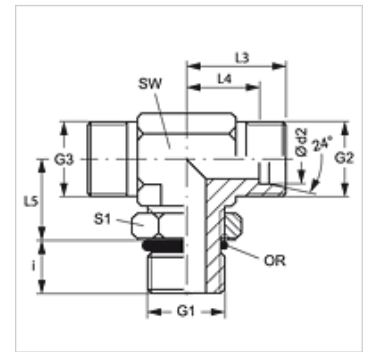

Poznámka

Pokyny pre montáž, zabudovanie, tlakové zaťaženie a povolené prevádzkové teploty nájdete v technických informáciách pre fittingové nákrutky

Výrobok

Označenie	Konštrukčný rad	Prevádzkový tlak	Ø d2 (mm)	G1	G2 + G3	i (mm)	L3 (mm)	L4 (mm)	L5 (mm)	SW (mm)	S1	OR
XETOR NW 04 HL	D	PN 315	6	G 1/8" -28	M 12 x 1,5	7	21	14	19	14	14	8,00 x 1,50
XETOR NW 06 HL	D	PN 315	8	G 1/4" -19	M 14 x 1,5	9	23	16	23	14	19	10,77 x 2,62
XETOR NW 08 HL	D	PN 315	10	G 1/4" -19	M 16 x 1,5	9	24	17	25	19	19	10,77 x 2,62
XETOR NW 10 HL	D	PN 250	12	G 3/8" -19	M 18 x 1,5	9	26	19	28	19	22	13,94 x 2,62
XETOR NW 13 HL	D	PN 250	15	G 1/2" -14	M 22 x 1,5	13	28	21	30	22	27	17,86 x 2,62
XETOR NW 16 HL	D	PN 250	18	G 1/2" -14	M 26 x 1,5	13	31	24	36	27	27	17,86 x 2,62
XETOR NW 20 HL	D	PN 160	22	G 3/4" -14	M 30 x 2	13	35	28	36	30	36	23,47 x 2,62
XETOR NW 25 HL	D	PN 160	28	G 1" -11	M 36 x 2	15	38	31	44	36	41	29,50 x 3,53
XETOR NW 32 HL	D	PN 160	35	G 1,1/4" -11	M 45 x 2	15	48	38	50	50	50	37,69 x 3,53
XETOR NW 40 HL	D	PN 160	42	G 1,1/2" -11	M 52 x 2	15	49	38	52	50	50	44,04 x 3,53
XETOR NW 03 HS	S	PN 315	6	G 1/4" -19	M 14 x 1,5	9	22	15	23	14	19	10,77 x 2,62
XETOR NW 04 HS	S	PN 315	8	G 1/4" -19	M 16 x 1,5	9	24	17	27	19	19	10,77 x 2,62
XETOR NW 06 HS	S	PN 250	10	G 3/8" -19	M 18 x 1,5	9	25	18	29	19	22	13,94 x 2,62
XETOR NW 08 HS	S	PN 250	12	G 3/8" -19	M 20 x 1,5	9	29	22	29	22	22	13,94 x 2,62
XETOR NW 10 HS	S	PN 250	14	G 1/2" -14	M 22 x 1,5	13	43	25	36	27	27	17,86 x 2,62
XETOR NW 13 HS	S	PN 250	16	G 1/2" -14	M 24 x 1,5	13	33	25	36	27	27	17,86 x 2,62
XETOR NW 16 HS	S	PN 250	20	G 3/4" -14	M 30 x 2	12	38	28	39	30	36	23,47 x 2,62
XETOR NW 20 HS	S	PN 250	25	G 1" -11	M 36 x 2	14	42	30	44	36	41	29,74 x 3,53
XETOR NW 25 HS	S	PN 160	30	G 1,1/4" -11	M 42 x 2	15	49	36	49	50	50	37,69 x 3,53
XETOR NW 32 HS	S	PN 160	38	G 1,1/2" -11	M 52 x 2	15	50	34	55	50	55	44,04 x 3,53

Konštrukčný rad: LL = Veľmi ľahká L = Ľahká S = Ťažká – PN = Menovitý tlak PB = Max. prevádzkový tlak – Ø d2 = Vonkajší priemer rúry