

V-LL MG / V-HL MG / V-HS MG

Nákrutka

HANSA FLEX

Vlastnosti

Prípojka 1	metrický vonkajší závit valcový
Tvar tesnenia 1	Vnútorný kužeľ 24°
Prípojka 2	metrický vonkajší závit valcový
Tvar tesnenia 2	Vnútorný kužeľ 24°
Konštrukcia	Nákrutka
Vyhotovenie	priame
Norma	ISO 8434-1
Rozsah dodávky	Hrdlo s presuvnou maticou a zárezným krúžkom
Materiál	Mosadz

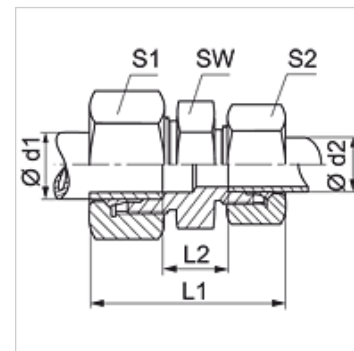

Poznámka

Pokyny pre montáž, zabudovanie, tlakové zaťaženie a povolené prevádzkové teploty nájdete v technických informáciách pre fittingové nákrutky

Výrobok

Označenie	Konštrukčný rad	Prevádzkový tlak	$\varnothing d1$ (mm)	$\varnothing d2$ (mm)	L1 (mm)	L2 (mm)	SW (mm)	S1	S2
V 04 LL MG	LL	PN 63	4	4	31,0	12	9	10	10
V 06 LL MG	LL	PN 63	6	6	32,0	9	11	12	12
V 08 LL MG	LL	PN 63	8	8	35,0	12	12	14	14
V 10 LL MG	LL	PN 63	10	10	35,0	12	14	17	17
V NW 04 HL MG	D	PN 200	6	6	39,0	10	12	14	14
V NW 06 HL 04 MG	D	PN 200	8	6	41,0	11	14	17	14
V NW 06 HL MG	D	PN 200	8	8	40,0	11	14	17	17
V NW 08 HL 04 MG	D	PN 200	10	6	42,0	12	17	19	14
V NW 08 HL 06 MG	D	PN 200	10	8	42,0	12	17	19	17
V NW 08 HL MG	D	PN 200	10	10	42,0	13	17	19	19
V NW 10 HL 04 MG	D	PN 200	12	6	42,0	13	19	22	14
V NW 10 HL 06 MG	D	PN 200	12	8	42,0	13	19	22	17
V NW 10 HL 08 MG	D	PN 200	12	10	44,0	14	19	22	19
V NW 10 HL MG	D	PN 200	12	12	43,0	14	19	22	22
V NW 13 HL 04 MG	D	PN 200	15	6	43,5	14	24	27	14
V NW 13 HL MG	D	PN 200	15	15	46,0	16	24	27	27
V NW 16 HL MG	D	PN 200	18	18	48,0	16	27	32	32
V NW 20 HL MG	D	PN 100	22	22	52,0	20	32	36	36
V NW 25 HL MG	D	PN 100	28	28	54,0	21	41	41	41
V NW 32 HL MG	D	PN 100	35	35	63,0	20	46	50	50
V NW 40 HL MG	D	PN 100	42	42	66,0	21	55	60	60
V NW 03 HS MG	S	PN 400	6	6	45,0	16	14	17	17
V NW 04 HS MG	S	PN 400	8	8	47,0	18	17	19	19
V NW 06 HS MG	S	PN 400	10	10	49,0	17	19	22	22
V NW 08 HS MG	S	PN 400	12	12	51,0	19	22	24	24
V NW 10 HS MG	S	PN 400	14	14	57,0	22	24	27	27
V NW 13 HS MG	S	PN 250	16	16	57,0	21	27	30	30
V NW 16 HS MG	S	PN 250	20	20	66,0	23	32	36	36
V NW 20 HS MG	S	PN 250	25	25	74,0	26	41	46	46
V NW 25 HS MG	S	PN 250	30	30	80,0	27	46	50	50
V NW 32 HS MG	S	PN 200	38	38	90,0	29	55	60	60

Konštrukčný rad: LL = Veľmi ľahká L = Ľahká S = Ťažká – PN = Menovitý tlak PB = Max. prevádzkový tlak – $\varnothing d1$ = Vonkajší priemer rúry – $\varnothing d2$ = Vonkajší priemer rúry

Variety produktu

V-LL / V-HL / V-HS	Nákrutka, Oceľ
V-LL VA / V-HL VA / V-HS VA	Nákrutka, Ušľachtilá oceľ