

XTRK VA

Nákrutka k naskrutkovaniu, tvar T

HANSA FLEX

Vlastnosti

| | |
|---------------------|---|
| Prípojka 1 | Vonkajší závit kužeľový BSPT |
| Tvar tesnenia 1 | tesniaci závit |
| Prípojka 2 + 3 | metrický vonkajší závit valcový |
| Tvar tesnenia 2 + 3 | Vnútorný kužeľ 24° |
| Konštrukcia | Nákrutka pre naskrutkovanie |
| Vyhotovenie | Tvar T |
| Norma | DIN 3906 |
| Rozsah dodávky | Hrdlo (bez presuvnej matice a zárezného krúžku) |
| Materiál | Ušľachtilá oceľ |

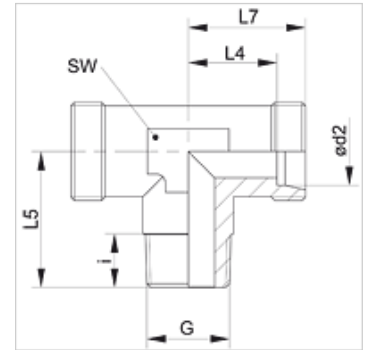

Výrobok

| Označenie | Konštrukčný rad | Prevádzkový tlak | Ø d2 (mm) | G | i (mm) | L4 (mm) | L5 (mm) | L7 (mm) | SW (mm) |
|---------------------|-----------------|------------------|-----------|----------|--------|---------|---------|---------|---------|
| XTR 04 LL VA | LL | PN 100 | 4 | R 1/8" K | 8 | 11,0 | 17 | 15 | 9 |
| XTR 06 LL VA | LL | PN 100 | 6 | R 1/8" K | 8 | 9,5 | 17 | 15 | 9 |
| XTR 08 LL VA | LL | PN 100 | 8 | R 1/8" K | 8 | 11,5 | 20 | 17 | 12 |
| XTR NW 04 HL VA | D | PN 315 | 6 | R 1/8" K | 8 | 12,0 | 20 | 19 | 12 |
| XTR NW 04 HL 1/4 VA | D | PN 315 | 6 | R 1/4" K | 12 | 14,0 | 26 | 21 | 12 |
| XTR NW 06 HL VA | D | PN 315 | 8 | R 1/4" K | 12 | 14,0 | 26 | 21 | 12 |
| XTR NW 06 HL 3/8 VA | D | PN 315 | 8 | R 3/8" K | 12 | 15,0 | 28 | 22 | 14 |
| XTR NW 08 HL VA | D | PN 315 | 10 | R 1/4" K | 12 | 15,0 | 27 | 22 | 14 |
| XTR NW 08 HL 3/8 VA | D | PN 315 | 10 | R 3/8" K | 12 | 15,0 | 27 | 22 | 17 |
| XTR NW 08 HL 1/2 VA | D | PN 315 | 10 | R 1/2" K | 14 | 21,0 | 33 | 29 | 17 |
| XTR NW 10 HL 1/4 VA | D | PN 315 | 12 | R 1/4" K | 12 | 17,0 | 28 | 24 | 17 |
| XTR NW 10 HL VA | D | PN 315 | 12 | R 3/8" K | 12 | 17,0 | 28 | 24 | 17 |
| XTR NW 10 HL 1/2 VA | D | PN 315 | 12 | R 1/2" K | 14 | 20,5 | 34 | 29 | 17 |
| XTR NW 13 HL VA | D | PN 315 | 15 | R 1/2" K | 14 | 21,0 | 34 | 28 | 19 |
| XTR NW 16 HL VA | D | PN 315 | 18 | R 1/2" K | 14 | 23,5 | 34 | 31 | 24 |
| XTR NW 03 HS VA | S | PN 400 | 6 | R 1/4" K | 12 | 16,0 | 26 | 23 | 12 |
| XTR NW 04 HS VA | S | PN 400 | 8 | R 1/4" K | 12 | 17,0 | 26 | 24 | 14 |
| XTR NW 06 HS VA | S | PN 400 | 10 | R 3/8" K | 12 | 17,5 | 27 | 25 | 17 |
| XTR NW 08 HS VA | S | PN 400 | 12 | R 3/8" K | 12 | 21,5 | 28 | 29 | 19 |
| XTR NW 08 HS 1/2 VA | S | PN 400 | 12 | R 1/2" K | 14 | 21,5 | 34 | 29 | 19 |
| XTR NW 10 HS VA | S | PN 400 | 14 | R 1/2" K | 14 | 22,0 | 32 | 30 | 19 |
| XTR NW 13 HS VA | S | PN 400 | 16 | R 1/2" K | 14 | 24,5 | 32 | 33 | 24 |

Konštrukčný rad: LL = Veľmi ľahká L = Ľahká S = Ťažká - PN = Menovitý tlak PB = Max. prevádzkový tlak - Ø = Vonkajší priemer rúrky

Variety produktu

| | |
|--------|--|
| XTRK | Nákrutka k naskrutkovaniu, tvar T, Oceľ |
| TRK VA | Nákrutka k naskrutkovaniu, tvar T, Ušľachtilá oceľ |