

Vlastnosti

Prípojka 1	metrický vonkajší závit valcový
Tvar tesnenia 1	Tvar B
Prípojka 2	metrický vonkajší závit valcový
Tvar tesnenia 2	Vnútny kužeľ 24°
Konštrukcia	Nákrutka pre naskrutkovanie
Vyhotovenie	priame
Norma	DIN 2353 ISO 8434-1
Rozsah dodávky	Hrdlo s presuvnou maticou a zárezným krúžkom
Materiál	Oceľ
Povrchová ochrana	galvanický povlak

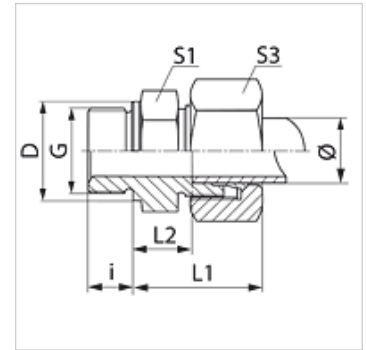

Poznámka

Pokyny pre montáž, zabudovanie, tlakové zaťaženie a povolené prevádzkové teploty nájdete v technických informáciách pre fittingové nákrutky

Výrobok

Označenie	Konštrukčný rad	Prevádzkový tlak	Rúrka, vonkajší Ø (mm)	G	D: (mm)	i (mm)	L1 (mm)	L2 (mm)	S1	S3
VM 16 LL	LL	PN 100	16	M 22 x 1,5	27	14	44,0	15,0	27	27
VM 16 LL 16-1.5	LL	PN 100	16	M 16 x 1,5	21	12	40,5	13,5	24	27
VM 16 LL 18-1.5	LL	PN 100	16	M 18 x 1,5	23	12	40,5	13,5	24	27
VM NW 04 HL	D	PN 315	6	M 10 x 1	14	8	23,0	8,5	14	14
VM NW 04 HL 12	D	PN 315	6	M 12 x 1,5	17	12	25,0	10,0	17	14
VM NW 04 HL 14	D	PN 315	6	M 14 x 1,5	19	12	25,0	10,0	19	14
VM NW 04 HL 16	D	PN 315	6	M 16 x 1,5	21	12	25,0	11,5	22	14
VM NW 04 HL 18	D	PN 315	6	M 18 x 1,5	23	12	24,5	11,5	24	14
VM NW 04 HL 22	D	PN 315	6	M 22 x 1,5	27	14	28,0	13,0	27	14
VM NW 06 HL	D	PN 315	8	M 12 x 1,5	17	12	25,0	10,0	17	17
VM NW 06 HL 10	D	PN 315	8	M 10 x 1	17	8	25,0	10,0	17	17
VM NW 06 HL 14	D	PN 315	8	M 14 x 1,5	19	12	25,0	10,0	19	17
VM NW 06 HL 16	D	PN 315	8	M 16 x 1,5	21	12	26,0	11,5	22	17
VM NW 06 HL 18	D	PN 315	8	M 18 x 1,5	23	12	26,0	11,5	24	17
VM NW 06 HL 22	D	PN 315	8	M 22 x 1,5	27	14	28,0	13,0	27	17
VM NW 08 HL	D	PN 315	10	M 14 x 1,5	19	12	26,0	11,0	19	19
VM NW 08 HL 12	D	PN 315	10	M 12 x 1,5	17	12	26,0	11,0	17	19
VM NW 08 HL 16	D	PN 315	10	M 16 x 1,5	22	12	27,5	12,5	22	19
VM NW 08 HL 18	D	PN 315	10	M 18 x 1,5	23	12	27,5	12,5	24	19
VM NW 08 HL 22	D	PN 315	10	M 22 x 1,5	27	14	29,0	14,0	27	19
VM NW 10 HL	D	PN 315	12	M 16 x 1,5	21	12	27,0	12,5	22	22
VM NW 10 HL 12	D	PN 315	12	M 12 x 1,5	17	12	26,0	11,0	19	22
VM NW 10 HL 14	D	PN 315	12	M 14 x 1,5	19	12	27,0	12,5	22	22
VM NW 10 HL 18	D	PN 315	12	M 18 x 1,5	23	12	27,0	12,5	24	22
VM NW 10 HL 22	D	PN 315	12	M 22 x 1,5	27	14	28,5	14,0	27	22
VM NW 10 HL 24	D	PN 315	12	M 24 x 1,5	27	14	28,5	14,0	27	22
VM NW 10 HL 26	D	PN 315	12	M 26 x 1,5	27	14	28,5	14,0	27	22
VM NW 13 HL	D	PN 315	15	M 18 x 1,5	23	12	29,0	13,5	24	27
VM NW 13 HL 14	D	PN 315	15	M 14 x 1,5	19	12	29,0	13,5	24	27
VM NW 13 HL 16	D	PN 315	15	M 16 x 1,5	21	12	29,0	13,5	24	27
VM NW 13 HL 22	D	PN 315	15	M 22 x 1,5	27	14	30,5	15,0	27	27
VM NW 13 HL 26	D	PN 315	15	M 26 x 1,5	31	16	30,5	15,0	32	27
VM NW 13 HL 30	D	PN 315	15	M 30 x 2	39	16	30,5	15,0	41	27
VM NW 16 HL	D	PN 315	18	M 22 x 1,5	27	14	31,0	14,5	27	32
VM NW 16 HL 18	D	PN 315	18	M 18 x 1,5	23	12	30,5	14,0	27	32
VM NW 16 HL 26	D	PN 315	18	M 26 x 1,5	31	16	31,0	14,5	32	32
VM NW 16 HL 27	D	PN 315	18	M 27 x 2	31	16	31,0	14,5	32	32
VM NW 16 HL 30-1.5	D	PN 315	18	M 30 x 1,5	39	16	31,0	15,0	41	27
VM NW 20 HL	D	PN 160	22	M 26 x 1,5	31	16	33,0	16,5	32	36
VM NW 20 HL 18	D	PN 160	22	M 18 x 1,5	27	14	31,0	14,5	27	36
VM NW 20 HL 22	D	PN 160	22	M 22 x 1,5	27	14	33,0	16,5	32	36



Výrobok

Označenie	Konštrukčný rad	Prevádzkový tlak	Rúrka, vonkajší Ø (mm)	G	D: (mm)	i (mm)	L1 (mm)	L2 (mm)	S1	S3
VM NW 20 HL 30-1.5	D	PN 160	22	M 30 x 1,5	39	14	33,0	16,5	41	36
VM NW 25 HL	D	PN 160	28	M 33 x 2	39	18	34,0	17,5	41	41
VM NW 25 HL 22	D	PN 160	28	M 22 x 1,5	27	18	34,0	17,5	32	41
VM NW 25 HL 26	D	PN 160	28	M 26 x 1,5	31	16	34,0	17,5	41	41
VM NW 25 HL 27	D	PN 160	28	M 27 x 2	39	20	34,0	17,5	41	41
VM NW 25 HL 42	D	PN 160	28	M 42 x 2	55	22	34,0	19,0	55	41
VM NW 32 HL	D	PN 160	35	M 42 x 2	49	20	39,0	17,5	50	50
VM NW 40 HL	D	PN 160	42	M 48 x 2	55	22	42,0	19,0	55	60
VM NW 03 HS	S	PN 400	6	M 12 x 1,5	17	12	28,0	13,0	17	17
VM NW 03 HS 16	S	PN 400	6	M 16 x 1,5	21	12	28,0	13,0	17	17
VM NW 03 HS 18	S	PN 400	6	M 18 x 1,5	27	14	28,0	13,0	19	17
VM NW 03 HS 22	S	PN 400	6	M 22 x 1,5	25	14	28,0	13,0	19	17
VM NW 04 HS	S	PN 400	8	M 14 x 1,5	19	12	30,0	15,0	19	19
VM NW 06 HS	S	PN 400	10	M 16 x 1,5	21	12	31,0	15,0	22	22
VM NW 06 HS 18	S	PN 400	10	M 18 x 1,5	27	14	31,0	15,0	22	22
VM NW 06 HS 22	S	PN 400	10	M 22 x 1,5	27	14	31,0	15,0	24	22
VM NW 08 HS	S	PN 400	12	M 18 x 1,5	23	12	33,0	17,0	24	24
VM NW 08 HS 14	S	PN 400	12	M 14 x 1,5	21	12	33,0	17,0	19	24
VM NW 08 HS 16	S	PN 400	12	M 16 x 1,5	21	12	29,0	17,0	24	24
VM NW 08 HS 22	S	PN 400	12	M 22 x 1,5	27	14	33,5	17,5	27	24
VM NW 10 HS	S	PN 400	14	M 20 x 1,5	25	14	37,0	19,0	27	27
VM NW 10 HS 16	S	PN 400	14	M 16 x 1,5	21	12	37,0	19,0	24	27
VM NW 10 HS 18	S	PN 400	14	M 18 x 1,5	27	14	37,0	19,0	24	27
VM NW 10 HS 22	S	PN 400	14	M 22 x 1,5	27	14	37,0	19,0	27	27
VM NW 13 HS	S	PN 400	16	M 22 x 1,5	27	14	37,0	18,5	27	30
VM NW 13 HS 16	S	PN 400	16	M 16 x 1,5	21	12	37,0	18,5	24	30
VM NW 13 HS 18	S	PN 400	16	M 18 x 1,5	23	12	37,0	18,5	27	30
VM NW 13 HS 26	S	PN 400	16	M 26 x 1,5	32	16	37,0	18,5	32	30
VM NW 16 HS	S	PN 400	20	M 27 x 2	32	16	42,0	20,5	32	36
VM NW 16 HS 22	S	PN 400	20	M 22 x 1,5	27	14	42,0	20,5	32	36
VM NW 16 HS 30-1.5	S	PN 400	20	M 30 x 1,5	39	18	42,0	20,5	36	36
VM NW 20 HS	S	PN 250	25	M 33 x 2	39	18	47,0	23,0	41	46
VM NW 20 HS 27	S	PN 250	25	M 27 x 2	32	16	47,0	23,0	41	46
VM NW 25 HS	S	PN 160	30	M 42 x 2	49	20	50,0	23,5	50	50
VM NW 32 HS	S	PN 160	38	M 48 x 2	55	22	57,0	26,0	55	60

Konštrukčný rad: LL = Veľmi ľahká L = Ľahká S = Ťažká – PN = Menovitý tlak PB = Max. prevádzkový tlak – Ø = Vonkajší priemer rúrky

Varianty produktu

VM MG	Nákrutka pre naskrutkovanie, Mosadz
VM VA	Nákrutka pre naskrutkovanie, Ušľachtilá oceľ
XVM	Nákrutka pre naskrutkovanie, Oceľ