

### Vlastnosti

Prípojka 1	metrický vonkajší závit valcový
Tvar tesnenia 1	Tvar B
Prípojka 2	metrický vonkajší závit valcový
Tvar tesnenia 2	Vnútorý kužeľ 24°
Konštrukcia	Nákrutka pre naskrutkovanie
Vyhotovenie	priame
Norma	DIN 2353 ISO 8434-1
Rozsah dodávky	Hrdlo s presuvnou maticou a zárezným krúžkom
Materiál	Ušľachtilá oceľ

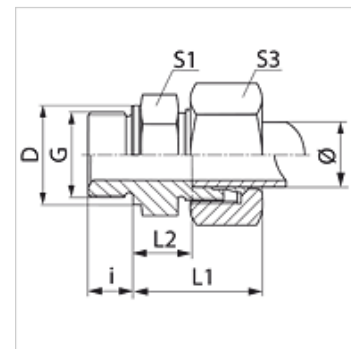

### Poznámka

Pokyny pre montáž, zabudovanie, tlakové zaťaženie a povolené prevádzkové teploty nájdete v technických informáciách pre fittingové nákrutky

### Výrobok

Označenie	Konštrukčný rad	Prevádzkový tlak	Rúrka, vonkajší Ø (mm)	G	D: (mm)	i (mm)	L1 (mm)	L2 (mm)	S1	S3
VM NW 04 HL VA	D	PN 315	6	M 10 x 1	14	8,0	23,0	8,5	14	14
VM NW 04 HL 12 VA	D	PN 315	6	M 12 x 1,5	17	12,0	25,0	10,0	17	14
VM NW 04 HL 14 VA	D	PN 315	6	M 14 x 1,5	19	12,0	25,0	10,0	19	14
VM NW 06 HL VA	D	PN 315	8	M 12 x 1,5	17	12,0	25,0	10,0	17	17
VM NW 06 HL 10 VA	D	PN 315	8	M 10 x 1	17	8,0	25,0	10,0	17	17
VM NW 06 HL 14 VA	D	PN 315	8	M 14 x 1,5	19	12,0	25,0	10,0	19	17
VM NW 06 HL 16 VA	D	PN 315	8	M 16 x 1,5	21	12,0	26,0	11,5	22	17
VM NW 06 HL 18 VA	D	PN 315	8	M 18 x 1,5	23	12,0	26,0	11,5	24	17
VM NW 08 HL VA	D	PN 315	10	M 14 x 1,5	19	12,0	26,0	11,0	19	19
VM NW 08 HL 10 VA	D	PN 315	10	M 10 x 1	14	8,0	26,0	11,0	17	19
VM NW 08 HL 12 VA	D	PN 315	10	M 12 x 1,5	17	12,0	26,0	11,0	17	19
VM NW 08 HL 16 VA	D	PN 315	10	M 16 x 1,5	22	12,0	27,5	12,5	22	19
VM NW 08 HL 18 VA	D	PN 315	10	M 18 x 1,5	23	12,0	27,5	12,5	24	19
VM NW 08 HL 22 VA	D	PN 315	10	M 22 x 1,5	27	14,0	29,0	14,0	27	19
VM NW 10 HL VA	D	PN 315	12	M 16 x 1,5	21	12,0	27,0	12,5	22	22
VM NW 10 HL 12 VA	D	PN 315	12	M 12 x 1,5	17	12,0	26,0	11,0	19	22
VM NW 10 HL 14 VA	D	PN 315	12	M 14 x 1,5	19	12,0	27,0	12,5	22	22
VM NW 10 HL 18 VA	D	PN 315	12	M 18 x 1,5	23	12,0	27,0	12,5	24	22
VM NW 10 HL 22 VA	D	PN 315	12	M 22 x 1,5	27	14,0	28,5	14,0	27	22
VM NW 13 HL VA	D	PN 315	15	M 18 x 1,5	23	12,0	29,0	13,5	24	27
VM NW 13 HL 16 VA	D	PN 315	15	M 16 x 1,5	21	12,0	29,0	13,5	24	27
VM NW 13 HL 22 VA	D	PN 315	15	M 22 x 1,5	27	14,0	30,5	15,0	27	27
VM NW 16 HL VA	D	PN 315	18	M 22 x 1,5	27	14,0	31,0	14,5	27	32
VM NW 16 HL 18 VA	D	PN 315	18	M 18 x 1,5	23	12,0	30,5	14,0	27	32
VM NW 16 HL 26 VA	D	PN 315	18	M 26 x 1,5	31	16,0	31,0	14,5	32	32
VM NW 20 HL VA	D	PN 160	22	M 26 x 1,5	31	16,0	33,0	16,5	32	36
VM NW 25 HL VA	D	PN 160	28	M 33 x 2	39	18,0	34,0	17,5	41	41
VM NW 32 HL VA	D	PN 160	35	M 42 x 2	49	20,0	39,0	17,5	50	50
VM NW 40 HL VA	D	PN 160	42	M 48 x 2	55	22,0	42,0	19,0	55	60
VM NW 03 HS VA	S	PN 400	6	M 12 x 1,5	17	12,0	28,0	13,0	17	17
VM NW 03 HS 14 VA	S	PN 400	6	M 14 x 1,5	19	12,0	30,0	15,0	19	17
VM NW 03 HS 16 VA	S	PN 400	6	M 16 x 1,5	21	12,0	28,0	13,0	17	17
VM NW 04 HS VA	S	PN 400	8	M 14 x 1,5	19	12,0	30,0	15,0	19	19
VM NW 06 HS VA	S	PN 400	10	M 16 x 1,5	21	12,0	31,0	15,0	22	22
VM NW 08 HS VA	S	PN 400	12	M 18 x 1,5	23	12,0	33,0	17,0	24	24
VM NW 08 HS 14 VA	S	PN 400	12	M 14 x 1,5	21	12,0	33,0	17,0	19	24
VM NW 10 HS VA	S	PN 400	14	M 20 x 1,5	25	14,0	37,0	19,0	27	27
VM NW 13 HS VA	S	PN 400	16	M 22 x 1,5	27	14,0	37,0	18,5	27	30
VM NW 13 HS 18 VA	S	PN 400	16	M 18 x 1,5	23	12,0	37,0	18,5	27	30
VM NW 16 HS VA	S	PN 400	20	M 27 x 2	32	16,0	42,0	20,5	32	36
VM NW 20 HS VA	S	PN 250	25	M 33 x 2	39	18,0	47,0	23,0	41	46
VM NW 25 HS VA	S	PN 160	30	M 42 x 2	49	20,0	50,0	23,5	50	50
VM NW 32 HS VA	S	PN 160	38	M 48 x 2	55	22,0	57,0	26,0	55	60



### Varianty produktu

<b>VM</b>	Nákrutka pre naskrutkovanie, Oceľ
-----------	-----------------------------------

<b>VM MG</b>	Nákrutka pre naskrutkovanie, Mosadz
--------------	-------------------------------------

<b>XVM VA</b>	Nákrutka pre naskrutkovanie, Ušľachtilá oceľ
---------------	--