

Vlastnosti

Prípojka 1	metrický vonkajší závit valcový
Tvar tesnenia 1	Tvar E
Prípojka 2	metrický vonkajší závit valcový
Tvar tesnenia 2	Vnútrotný kužeľ 24°
Konštrukcia	Nákrutka pre naskrutkovanie
Vyhotovenie	priame
Norma	DIN 2353 ISO 8434-1
Rozsah dodávky	Hrdlo s presuvnou maticou a zárezným krúžkom
Materiál	Ušľachtilá oceľ

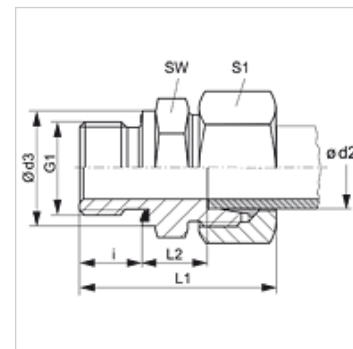

Poznámka

Pokyny pre montáž, zabudovanie, tlakové zaťaženie a povolené prevádzkové teploty nájdete v technických informáciách pre fittingové nákrutky

Pokyny pre objednanie

NBR tesnenie

FPM (Viton) na vyžiadanie

Výrobok

Označenie	Konštrukčný rad	Prevádzkový tlak	Ø d2 (mm)	G1	Ø d3 (mm)	i (mm)	L1 (mm)	L2 (mm)	SW (mm)	S1
VM NW 04 HL ED VA	D	PN 315	6	M 10 x 1	14,0	8	31,0	8,5	14	14
VM NW 04 HL 12 ED VA	D	PN 315	6	M 12 x 1,5	17,0	12	36,5	8,5	17	14
VM NW 04 HL 14 ED VA	D	PN 315	6	M 14 x 1,5	19,0	12	39,0	10,0	19	14
VM NW 06 HL 10 ED VA	D	PN 315	8	M 10 x 1	14,0	8	34,0	9,5	17	17
VM NW 06 HL ED VA	D	PN 315	8	M 12 x 1,5	17,0	12	37,0	10,0	17	17
VM NW 06 HL 14 ED VA	D	PN 315	8	M 14 x 1,5	19,0	12	39,0	10,0	19	17
VM NW 06 HL 16 ED VA	D	PN 315	8	M 16 x 1,5	21,7	12	39,5	10,0	22	17
VM NW 06 HL 18 ED VA	D	PN 315	8	M 18 x 1,5	24,0	12	39,5	10,0	24	17
VM NW 08 HL 10 ED VA	D	PN 315	10	M 10 x 1	14,0	8	34,0	11,0	17	19
VM NW 08 HL 12 ED VA	D	PN 315	10	M 12 x 1,5	17,0	12	40,5	11,0	17	19
VM NW 08 HL ED VA	D	PN 315	10	M 14 x 1,5	19,0	12	38,0	11,0	19	19
VM NW 08 HL 16 ED VA	D	PN 315	10	M 16 x 1,5	21,7	12	38,0	12,5	22	19
VM NW 08 HL 18 ED VA	D	PN 315	10	M 18 x 1,5	23,7	12	42,0	12,5	24	19
VM NW 08 HL 22 ED VA	D	PN 315	10	M 22 x 1,5	27,0	14	44,0	12,5	27	19
VM NW 10 HL 12 ED VA	D	PN 315	12	M 12 x 1,5	17,0	12	40,0	13,0	19	22
VM NW 10 HL 14 ED VA	D	PN 315	12	M 14 x 1,5	19,0	12	40,0	11,0	19	22
VM NW 10 HL ED VA	D	PN 315	12	M 16 x 1,5	21,7	12	39,0	12,5	22	22
VM NW 10 HL 18 ED VA	D	PN 315	12	M 18 x 1,5	23,7	12	42,0	17,0	24	22
VM NW 10 HL 22 ED VA	D	PN 315	12	M 22 x 1,5	27,0	14	46,0	14,0	27	22
VM NW 13 HL ED VA	D	PN 315	15	M 18 x 1,5	23,7	12	41,0	13,5	24	27
VM NW 13 HL 16 ED VA	D	PN 315	15	M 16 x 1,5	22,0	12	44,0	13,0	24	27
VM NW 13 HL 22 ED VA	D	PN 315	15	M 22 x 1,5	27,0	14	47,0	14,5	27	27
VM NW 16 HL 18 ED VA	D	PN 315	18	M 18 x 1,5	24,0	12	45,0	14,0	27	32
VM NW 16 HL ED VA	D	PN 315	18	M 22 x 1,5	27,0	14	45,0	14,5	27	32
VM NW 20 HL ED VA	D	PN 160	22	M 26 x 1,5	31,7	16	49,0	16,5	32	36
VM NW 25 HL ED VA	D	PN 160	28	M 33 x 2	39,7	18	52,0	17,5	41	41
VM NW 32 HL ED VA	D	PN 160	35	M 42 x 2	49,7	20	59,0	17,5	50	50
VM NW 40 HL ED VA	D	PN 160	42	M 48 x 2	55,0	22	64,0	19,0	55	60
VM NW 03 HS ED VA	S	PN 630	6	M 12 x 1,5	17,0	12	40,0	13,0	17	17
VM NW 03 HS 14 ED VA	S	PN 315	6	M 14 x 1,5	19,0	12	40,0	10,0	19	14
VM NW 04 HS ED VA	S	PN 630	8	M 14 x 1,5	19,0	12	42,0	15,0	19	19
VM NW 06 HS ED VA	S	PN 630	10	M 16 x 1,5	21,7	12	43,0	15,0	22	22
VM NW 08 HS 14 ED VA	S	PN 630	12	M 14 x 1,5	19,0	12	45,0	16,5	22	24
VM NW 08 HS ED VA	S	PN 630	12	M 18 x 1,5	23,7	12	45,0	17,0	24	24
VM NW 10 HS ED VA	S	PN 630	14	M 20 x 1,5	25,7	14	53,0	19,0	27	27
VM NW 13 HS 18 ED VA	S	PN 630	16	M 18 x 1,5	24,0	12	48,5	18,0	27	30
VM NW 13 HS ED VA	S	PN 400	16	M 22 x 1,5	27,0	14	51,0	18,5	27	30



Výrobok

Označenie	Konštrukčný rad	Prevádzkový tlak	Ø d2 (mm)	G1	Ø d3 (mm)	i (mm)	L1 (mm)	L2 (mm)	SW (mm)	S1
VM NW 16 HS ED VA	S	PN 400	20	M 27 x 2	32,0	16	53,0	20,5	32	36
VM NW 20 HS ED VA	S	PN 400	25	M 33 x 2	39,7	18	65,0	23,0	41	46
VM NW 25 HS ED VA	S	PN 400	30	M 42 x 2	49,7	20	70,0	23,5	50	50
VM NW 32 HS ED VA	S	PN 315	38	M 48 x 2	55,0	22	79,0	26,0	55	60

Konštrukčný rad: LL = Veľmi ľahká L = Ľahká S = Ťažká – PN = Menovitý tlak PB = Max. prevádzkový tlak – Ø d2 = Vonkajší priemer rúry

Varianty produktu

VM ED

XVM ED VA

Náhradné diely

WD V Mäkké tesnenie JIC