

Vlastnosti

Prípojka 1	Vonkajší závit NPT
Tvar tesnenia 1	tesniaci závit
Prípojka 2	metrický vonkajší závit valcový
Tvar tesnenia 2	Vnútný kužeľ 24°
Konštrukcia	Nákrutka pre naskrutkovanie
Vyhotovenie	priame
Norma	DIN 2353 ISO 8434-1
Rozsah dodávky	Hrdlo s presuvnou maticou a zárezným krúžkom
Materiál	Oceľ
Povrchová ochrana	galvanický povlak

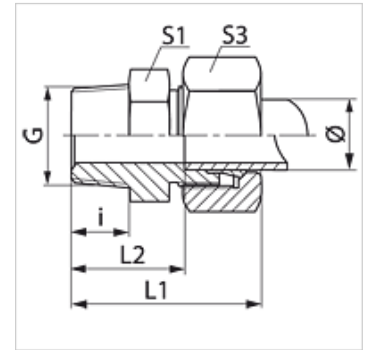

Poznámka

Pokyny pre montáž, zabudovanie, tlakové zaťaženie a povolené prevádzkové teploty nájdete v technických informáciách pre fittingové nákrutky

Výrobok

Označenie	Konštrukčný rad	Prevádzkový tlak	Rúrka, vonkajší Ø (mm)	G	i (mm)	L1 (mm)	L2 (mm)	S1	S3
VN 04 LL	LL	PN 100	4	1/8" -27 NPT	10,0	28,0	18,0	11	10
VN 05 LL	LL	PN 100	5	1/8" -27 NPT	10,0	28,0	16,5	11	12
VN 06 LL	LL	PN 100	6	1/8" -27 NPT	10,0	28,0	16,5	11	12
VN 08 LL	LL	PN 100	8	1/8" -27 NPT	10,0	30,0	18,5	12	14
VN NW 04 HL	D	PN 315	6	1/8" -27 NPT	10,0	32,0	17,0	12	14
VN NW 04 HL 1/4	D	PN 315	6	1/4" -18 NPT	15,0	38,0	23,0	17	14
VN NW 04 HL 3/8	D	PN 315	6	3/8" -18 NPT	15,0	39,0	24,0	19	14
VN NW 04 HL 1/2	D	PN 315	6	1/2" -14 NPT	20,0	44,0	29,0	24	14
VN NW 06 HL 1/8	D	PN 315	8	1/8" -27 NPT	10,0	38,0	23,0	12	17
VN NW 06 HL	D	PN 315	8	1/4" -18 NPT	15,0	38,0	23,0	17	17
VN NW 06 HL 3/8	D	PN 315	8	3/8" -18 NPT	15,5	39,0	24,0	19	17
VN NW 06 HL 1/2	D	PN 315	8	1/2" -14 NPT	20,0	44,0	29,0	24	17
VN NW 08 HL 1/8	D	PN 315	10	1/8" -27 NPT	15,5	39,5	25,0	17	19
VN NW 08 HL	D	PN 315	10	1/4" -18 NPT	15,0	39,0	24,0	17	19
VN NW 08 HL 3/8	D	PN 315	10	3/8" -18 NPT	15,2	40,0	25,0	19	19
VN NW 08 HL 1/2	D	PN 315	10	1/2" -14 NPT	20,0	45,0	30,0	24	19
VN NW 10 HL 1/8	D	PN 315	12	1/8" -27 NPT	15,0	40,0	25,0	19	22
VN NW 10 HL 1/4	D	PN 315	12	1/4" -18 NPT	15,0	40,0	25,0	19	22
VN NW 10 HL	D	PN 315	12	3/8" -18 NPT	15,5	40,0	25,0	19	22
VN NW 10 HL 1/2	D	PN 315	12	1/2" -14 NPT	20,0	45,0	30,0	24	22
VN NW 10 HL 3/4	D	PN 315	12	3/4" -14 NPT	20,0	45,0	32,0	27	22
VN NW 13 HL 1/4	D	PN 315	15	1/4" -18 NPT	15,0	40,0	25,0	24	22
VN NW 13 HL 3/8	D	PN 315	15	3/8" -18 NPT	15,5	41,5	26,5	24	27
VN NW 13 HL	D	PN 315	15	1/2" -14 NPT	20,0	46,0	31,0	24	27
VN NW 13 HL 3/4	D	PN 315	15	3/4" -14 NPT	20,0	46,0	32,0	27	27
VN NW 16 HL 1/4	D	PN 315	18	1/4" -18 NPT	15,0	32,0	25,0	27	32
VN NW 16 HL	D	PN 315	18	1/2" -14 NPT	20,0	48,0	31,5	27	32
VN NW 16 HL 3/4	D	PN 315	18	3/4" -14 NPT	20,0	48,5	32,0	27	32
VN NW 20 HL 1/2	D	PN 160	22	1/2" -14 NPT	20,0	50,0	33,5	32	36
VN NW 20 HL	D	PN 160	22	3/4" -14 NPT	20,0	50,0	33,5	32	36
VN NW 25 HL	D	PN 160	28	1" -11,5 NPT	25,0	56,0	39,5	41	41
VN NW 32 HL 1	D	PN 160	35	1" -11,5 NPT	25,0	62,0	40,5	46	50
VN NW 32 HL	D	PN 160	35	1,1/4" -11,5 NPT	25,5	62,0	40,5	46	50
VN NW 40 HL	D	PN 160	42	1,1/2" -11,5 NPT	26,0	65,0	42,0	55	60
VN NW 03 HS	S	PN 630	6	1/4" -18 NPT	15,0	43,0	28,0	17	17
VN NW 03 HS 1/2	S	PN 630	6	1/2" -14 NPT	20,0	50,0	35,0	24	17
VN NW 04 HS	S	PN 630	8	1/4" -18 NPT	15,0	43,0	28,0	17	19
VN NW 04 HS 3/8	S	PN 630	8	3/8" -18 NPT	15,5	43,0	28,0	19	19
VN NW 06 HS 1/4	S	PN 630	10	1/4" -18 NPT	15,0	44,0	27,5	19	22
VN NW 06 HS	S	PN 630	10	3/8" -18 NPT	15,5	44,0	27,5	19	22



Výrobok

Označenie	Konštrukčný rad	Prevádzkový tlak	Rúrka, vonkajší Ø (mm)	G	i (mm)	L1 (mm)	L2 (mm)	S1	S3
VN NW 06 HS 1/2	S	PN 400	10	1/2" -14 NPT	20,0	51,0	34,5	24	22
VN NW 08 HS 1/4	S	PN 630	12	1/4" -18 NPT	15,1	46,0	29,5	22	24
VN NW 08 HS	S	PN 630	12	3/8" -18 NPT	15,5	46,0	29,5	22	24
VN NW 08 HS 1/2	S	PN 630	12	1/2" -14 NPT	20,0	51,0	34,5	24	24
VN NW 10 HS 3/8	S	PN 630	14	3/8" -18 NPT	15,5	54,0	36,0	24	27
VN NW 10 HS	S	PN 630	14	1/2" -14 NPT	20,0	54,0	36,0	24	27
VN NW 13 HS	S	PN 400	16	1/2" -14 NPT	20,0	54,0	35,5	27	30
VN NW 13 HS 3/4	S	PN 400	16	3/4" -14 NPT	20,0	56,0	37,5	32	30
VN NW 16 HS 1/2	S	PN 400	20	1/2" -14 NPT	20,0	59,0	37,5	32	30
VN NW 16 HS	S	PN 400	20	3/4" -14 NPT	20,0	59,0	37,5	32	36
VN NW 16 HS 1	S	PN 400	20	1" -11,5 NPT	25,0	66,0	44,5	41	36
VN NW 20 HS 3/4	S	PN 400	25	3/4" -14 NPT	20,0	64,0	40,0	41	46
VN NW 20 HS	S	PN 400	25	1" -11,5 NPT	25,0	69,0	45,0	41	46
VN NW 20 HS 1 1/4	S	PN 400	25	1,1/4" -11,5 NPT	25,5	69,0	45,5	46	46
VN NW 25 HS 1	S	PN 400	30	1" -11,5 NPT	25,0	66,5	40,0	46	50
VN NW 25 HS	S	PN 400	30	1,1/4" -11,5 NPT	25,5	73,0	46,5	46	50
VN NW 32 HS	S	PN 315	38	1,1/2" -11,5 NPT	26,0	80,0	49,0	55	60

Konštrukčný rad: LL = Veľmi ľahká L = Ľahká S = Ťažká – PN = Menovitý tlak PB = Max. prevádzkový tlak – Ø = Vonkajší priemer rúrky

Varianty produktu

VN MG	Nákrutka pre naskrutkovanie, Mosadz
VN VA	Nákrutka pre naskrutkovanie, Ušľachtilá oceľ
XVN	Nákrutka pre naskrutkovanie, Oceľ