

Vlastnosti

Prípojka 1	Vonkajší závit BSP, valcový
Tvar tesnenia 1	Tvar B
Prípojka 2	metrický vonkajší závit valcový
Tvar tesnenia 2	Vnútorý kužeľ 24°
Konštrukcia	Nákrutka pre naskrutkovanie
Vyhotovenie	priame
Norma	DIN 2353 ISO 8434-1
Rozsah dodávky	Hrdlo s presuvnou maticou a zárezným krúžkom
Materiál	Oceľ
Povrchová ochrana	galvanický povlak

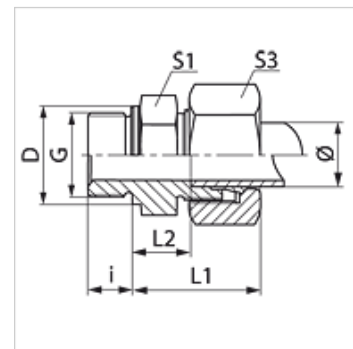

Poznámka

Pokyny pre montáž, zabudovanie, tlakové zaťaženie a povolené prevádzkové teploty nájdete v technických informáciách pre fittingové nákrutky

Výrobok

Označenie	Konštrukčný rad	Prevádzkový tlak	Rúrka, vonkajší Ø (mm)	G	D: (mm)	i (mm)	L1 (mm)	L2 (mm)	S1	S3
VR NW 04 HL	D	PN 315	6	G 1/8" -28	14	8	23,0	8,5	14	14
VR NW 04 HL 1/4	D	PN 315	6	G 1/4" -19	18	12	24,5	10,0	19	14
VR NW 04 HL 3/8	D	PN 315	6	G 3/8" -19	22	12	26,0	11,5	22	14
VR NW 04 HL 1/2	D	PN 315	6	G 1/2" -14	26	14	26,5	12,0	27	14
VR NW 06 HL 1/8	D	PN 315	8	G 1/8" -28	14	8	24,0	9,0	14	17
VR NW 06 HL	D	PN 315	8	G 1/4" -19	18	12	25,0	10,0	19	17
VR NW 06 HL 3/8	D	PN 315	8	G 3/8" -19	22	12	26,5	11,5	22	17
VR NW 06 HL 1/2	D	PN 315	8	G 1/2" -14	26	14	27,0	12,0	27	17
VR NW 08 HL 1/8	D	PN 315	10	G 1/8" -28	14	8	25,5	10,5	17	19
VR NW 08 HL	D	PN 315	10	G 1/4" -19	18	12	26,0	11,0	19	19
VR NW 08 HL 3/8	D	PN 315	10	G 3/8" -19	22	12	27,5	12,5	22	19
VR NW 08 HL 1/2	D	PN 315	10	G 1/2" -14	26	14	28,0	13,0	27	19
VR NW 10 HL 1/8	D	PN 315	12	G 1/8" -28	14	8	27,0	12,0	17	22
VR NW 10 HL 1/4	D	PN 315	12	G 1/4" -19	18	12	26,5	12,0	19	22
VR NW 10 HL	D	PN 315	12	G 3/8" -19	22	12	27,0	12,5	22	22
VR NW 10 HL 1/2	D	PN 315	12	G 1/2" -14	26	14	27,5	13,0	27	22
VR NW 10 HL 3/4	D	PN 315	12	G 3/4" -14	32	16	28,5	14,0	32	22
VR NW 13 HL 1/4	D	PN 315	15	G 1/4" -19	18	12	29,0	14,0	19	27
VR NW 13 HL 3/8	D	PN 315	15	G 3/8" -19	22	12	29,0	14,0	24	27
VR NW 13 HL	D	PN 315	15	G 1/2" -14	26	14	29,0	14,0	27	27
VR NW 13 HL 3/4	D	PN 315	15	G 3/4" -14	32	16	30,0	15,0	32	27
VR NW 16 HL 3/8	D	PN 315	18	G 3/8" -19	22	12	30,5	14,0	27	32
VR NW 16 HL	D	PN 315	18	G 1/2" -14	26	14	31,0	14,5	27	32
VR NW 16 HL 3/4	D	PN 315	18	G 3/4" -14	32	16	31,0	14,5	32	32
VR NW 16 HL 1	D	PN 315	18	G 1" -11	39	18	31,0	17,5	41	32
VR NW 20 HL 1/2	D	PN 160	22	G 1/2" -14	26	14	33,0	16,5	32	36
VR NW 20 HL	D	PN 160	22	G 3/4" -14	32	16	33,0	16,5	32	36
VR NW 20 HL 1	D	PN 160	22	G 1" -11	39	18	34,0	17,5	41	36
VR NW 25 HL 1/2	D	PN 160	28	G 1/2" -14	26	14	33,0	18,5	41	41
VR NW 25 HL 3/4	D	PN 160	28	G 3/4" -14	32	16	34,0	17,5	41	41
VR NW 25 HL	D	PN 160	28	G 1" -11	39	18	34,0	17,5	41	41
VR NW 25 HL 1 1/4	D	PN 160	28	G 1,1/4" -11	49	20	39,0	17,5	50	41
VR NW 32 HL 3/4	D	PN 160	35	G 3/4" -14	32	16	39,0	17,5	41	50
VR NW 32 HL 1	D	PN 160	35	G 1" -11	39	18	40,0	18,5	50	50
VR NW 32 HL	D	PN 160	35	G 1,1/4" -11	49	20	39,0	17,5	50	50
VR NW 32 HL 1 1/2	D	PN 160	35	G 1,1/2" -11	55	22	40,0	19,0	55	50
VR NW 40 HL 1 1/4	D	PN 160	42	G 1,1/4" -11	49	20	42,0	17,5	50	60
VR NW 40 HL	D	PN 160	42	G 1,1/2" -11	55	22	42,0	19,0	55	60
VR NW 03 HS 1/8	S	PN 400	6	G 1/8" -28	14	8	28,0	12,0	17	17
VR NW 03 HS	S	PN 400	6	G 1/4" -19	18	12	28,0	13,0	19	17
VR NW 03 HS 3/8	S	PN 400	6	G 3/8" -19	22	12	32,5	17,5	22	17



Výrobok

Označenie	Konštrukčný rad	Prevádzkový tlak	Rúrka, vonkajší Ø (mm)	G	D: (mm)	i (mm)	L1 (mm)	L2 (mm)	S1	S3
VR NW 03 HS 1/2	S	PN 400	6	G 1/2" -14	26	14	33,0	18,0	27	17
VR NW 04 HS	S	PN 400	8	G 1/4" -19	18	12	30,0	15,0	19	19
VR NW 04 HS 3/8	S	PN 400	8	G 3/8" -19	22	12	30,5	15,5	22	19
VR NW 04 HS 1/2	S	PN 400	8	G 1/2" -14	26	14	34,0	17,5	27	19
VR NW 06 HS 1/4	S	PN 400	10	G 1/4" -19	18	12	30,5	14,5	22	22
VR NW 06 HS	S	PN 400	10	G 3/8" -19	22	12	31,0	15,0	22	22
VR NW 06 HS 1/2	S	PN 400	10	G 1/2" -14	26	14	33,5	17,5	27	22
VR NW 08 HS 1/4	S	PN 400	12	G 1/4" -19	18	12	32,5	16,5	22	24
VR NW 08 HS	S	PN 400	12	G 3/8" -19	22	12	33,0	17,0	22	24
VR NW 08 HS 1/2	S	PN 400	12	G 1/2" -14	26	14	33,5	17,5	27	24
VR NW 08 HS 3/4	S	PN 400	12	G 3/4" -14	32	16	35,0	19,0	32	24
VR NW 10 HS 3/8	S	PN 400	14	G 3/8" -19	22	12	36,5	18,5	24	27
VR NW 10 HS	S	PN 400	14	G 1/2" -14	26	14	37,0	19,0	27	27
VR NW 10 HS 3/4	S	PN 400	14	G 3/4" -14	32	16	36,5	18,5	32	27
VR NW 13 HS 1/4	S	PN 400	16	G 1/4" -19	22	12	37,0	18,5	27	30
VR NW 13 HS 3/8	S	PN 400	16	G 3/8" -19	22	12	37,0	18,5	27	30
VR NW 13 HS	S	PN 400	16	G 1/2" -14	26	14	37,0	18,5	27	30
VR NW 13 HS 3/4	S	PN 400	16	G 3/4" -14	32	16	39,0	20,5	32	30
VR NW 16 HS 1/2	S	PN 400	20	G 1/2" -14	26	14	44,0	22,5	32	36
VR NW 16 HS	S	PN 400	20	G 3/4" -14	39	18	44,0	22,5	32	36
VR NW 16 HS 1	S	PN 250	20	G 1" -11	39	18	42,0	17,5	41	36
VR NW 20 HS 1/2	S	PN 250	25	G 1/2" -14	26	14	47,0	26,5	41	46
VR NW 20 HS 3/4	S	PN 250	25	G 3/4" -14	32	16	47,0	23,0	41	46
VR NW 20 HS	S	PN 250	25	G 1" -11	39	18	47,0	23,0	41	46
VR NW 20 HS 1 1/4	S	PN 160	25	G 1,1/4" -11	49	20	47,0	23,0	50	46
VR NW 25 HS 3/4	S	PN 160	30	G 3/4" -14	32	16	50,0	23,5	46	50
VR NW 25 HS 1	S	PN 160	30	G 1" -11	39	18	50,0	23,5	46	50
VR NW 25 HS 1 1/2	S	PN 160	30	G 1,1/2" -11	55	22	50,0	23,5	55	50
VR NW 25 HS	S	PN 160	30	G 1,1/4" -11	49	20	50,0	23,5	50	50
VR NW 32 HS 1	S	PN 160	38	G 1" -11	39	18	57,0	26,0	55	60
VR NW 32 HS 1 1/4	S	PN 160	38	G 1,1/4" -11	49	20	57,0	26,0	55	60
VR NW 32 HS	S	PN 160	38	G 1,1/2" -11	55	22	57,0	26,0	55	60

Konštrukčný rad: LL = Veľmi ľahká L = Ľahká S = Ťažká - PN = Menovitý tlak PB = Max. prevádzkový tlak - Ø = Vonkajší priemer rúrky

Variety produktu

VR MG	Nákrutka pre naskrutkovanie, Mosadz
VR VA	Nákrutka pre naskrutkovanie, Ušľachtilá oceľ
XVR	Nákrutka pre naskrutkovanie, Oceľ