

Vlastnosti

Prípojka 1	Vonkajší závit kužeľový BSPT
Tvar tesnenia 1	tesniaci závit
Prípojka 2	metrický vonkajší závit valcový
Tvar tesnenia 2	Vnútny kužeľ 24°
Konštrukcia	Nákrutka pre naskrutkovanie
Vyhotovenie	priame
Norma	DIN 2353 ISO 8434-1
Rozsah dodávky	Hrdlo s presuvnou maticou a zárezným krúžkom
Materiál	Oceľ
Povrchová ochrana	galvanický povlak

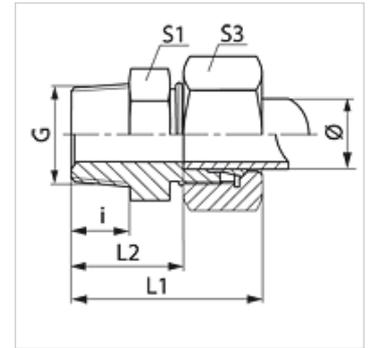

Poznámka

Pokyny pre montáž, zabudovanie, tlakové zaťaženie a povolené prevádzkové teploty nájdete v technických informáciách pre fittingové nákrutky

Výrobok

Označenie	Konštrukčný rad	Prevádzkový tlak	Rúrka, vonkajší Ø (mm)	G	i (mm)	L1 (mm)	L2 (mm)	S1	S3
VR 04 LL	LL	PN 100	4	R 1/8" K	8	26	16,0	11	10
VR 05 LL	LL	PN 100	5	R 1/8" K	8	26	14,5	11	12
VR 06 LL	LL	PN 100	6	R 1/8" K	8	26	14,5	11	12
VR 06 LL 1/4	LL	PN 100	6	R 1/4" K	12	26	14,5	12	12
VR 08 LL	LL	PN 100	8	R 1/8" K	8	28	16,5	12	14
VR 08 LL 1/4	LL	PN 100	8	R 1/4" K	13	33	21,5	17	14
VR 10 LL	LL	PN 100	10	R 1/4" K	12	32	20,5	14	17
VR 12 LL	LL	PN 100	12	R 1/4" K	12	32	20,0	17	19
VR 12 LL 3/8	LL	PN 100	12	R 3/8" K	14	32	20,0	19	19
VRK NW 04 HL	D	PN 315	6	R 1/8" K	10	32	17,0	12	14
VRK NW 04 HL 1/4	D	PN 315	6	R 1/4" K	13	36	21,0	17	14
VRK NW 06 HL 1/8	D	PN 315	8	R 1/8" K	8	31	16,0	14	17
VRK NW 06 HL	D	PN 315	8	R 1/4" K	13	36	21,0	17	17
VRK NW 06 HL 3/8	D	PN 315	8	R 3/8" K	12	36	21,0	19	17
VRK NW 06 HL 1/2	D	PN 315	8	R 1/2" K	14	38	23,0	22	17
VRK NW 08 HL 1/8	D	PN 315	10	R 1/8" K	10	26	19,0	17	19
VRK NW 08 HL	D	PN 315	10	R 1/4" K	13	37	22,0	17	19
VRK NW 08 HL 3/8	D	PN 315	10	R 3/8" K	12	37	22,0	19	19
VRK NW 08 HL 1/2	D	PN 315	10	R 1/2" K	14	39	24,0	22	19
VRK NW 10 HL 1/4	D	PN 315	12	R 1/4" K	13	38	23,0	19	22
VRK NW 10 HL	D	PN 315	12	R 3/8" K	13	38	23,0	19	22
VRK NW 10 HL 1/2	D	PN 315	12	R 1/2" K	16	41	26,0	24	22
VRK NW 13 HL 3/8	D	PN 315	15	R 3/8" K	13	39	24,0	24	27
VRK NW 13 HL	D	PN 315	15	R 1/2" K	16	42	27,0	24	27
VRK NW 16 HL 3/8	D	PN 315	18	R 3/8" K	13	31	14,5	27	32
VRK NW 16 HL	D	PN 315	18	R 1/2" K	16	44	27,5	27	32
VRK NW 16 HL 3/4	D	PN 160	18	R 3/4" K	18	32	29,5	32	32
VRK NW 20 HL 1/2	D	PN 160	22	R 1/2" K	16	46	27,5	27	36
VRK NW 20 HL	D	PN 160	22	R 3/4" K	18	48	31,5	32	36
VRK NW 25 HL	D	PN 160	28	R 1" K	20	34	34,5	41	41
VRK NW 32 HL 1	D	PN 160	35	R 1" K	20	34	34,5	41	41
VRK NW 32 HL	D	PN 160	35	R 1,1/4" K	21	39	36,5	46	50
VRK NW 40 HL	D	PN 160	42	R 1,1/2" K	22	42	38,0	55	60
VRK NW 03 HS	S	PN 400	6	R 1/4" K	13	41	26,0	17	17
VRK NW 04 HS	S	PN 400	8	R 1/4" K	13	41	26,0	17	19
VRK NW 06 HS 1/4	S	PN 400	10	R 1/4" K	13	41	26,0	17	22
VRK NW 06 HS	S	PN 400	10	R 3/8" K	13	42	25,5	19	22
VRK NW 08 HS 1/4	S	PN 400	12	R 1/4" K	13	46	27,5	22	24
VRK NW 08 HS	S	PN 400	12	R 3/8" K	13	44	27,5	22	24
VRK NW 08 HS 1/2	S	PN 400	12	R 1/2" K	16	49	30,5	22	24



Výrobok

Označenie	Konštrukčný rad	Prevádzkový tlak	Rúrka, vonkajší Ø (mm)	G	i (mm)	L1 (mm)	L2 (mm)	S1	S3
VRK NW 10 HS 3/8	S	PN 400	14	R 3/8" K	13	50	29,0	24	24
VRK NW 10 HS	S	PN 400	14	R 1/2" K	16	50	32,0	24	27
VRK NW 13 HS 3/8	S	PN 400	16	R 3/8" K	13	50	30,0	27	30
VRK NW 13 HS	S	PN 400	16	R 1/2" K	14	51	32,5	27	30
VRK NW 16 HS	S	PN 400	20	R 3/4" K	18	60	35,5	32	36
VRK NW 20 HS	S	PN 400	25	R 1" K	20	67	38,0	41	46
VRK NW 25 HS 1	S	PN 400	30	R 1" K	20	70	39,5	41	50
VRK NW 25 HS	S	PN 400	30	R 1,1/4" K	21	71	40,5	46	50
VRK NW 32 HS 1 1/4	S	PN 315	38	R 1,1/4" K	21	78	43,0	55	50
VRK NW 32 HS	S	PN 315	38	R 1,1/2" K	22	79	44,0	55	60

Konštrukčný rad: LL = Veľmi ľahká L = Ľahká S = Ťažká – PN = Menovitý tlak PB = Max. prevádzkový tlak – Ø = Vonkajší priemer rúrky

Varianty produktu

VRK MG	Nákrutka pre naskrutkovanie, Mosadz
VRK VA	Nákrutka pre naskrutkovanie, Ušľachtilá oceľ
XVRK	Nákrutka pre naskrutkovanie, Oceľ