

Vlastnosti

Prípojka 1	Vonkajší závit UN/UNF
Tvar tesnenia 1	Tvar F s tesnením na závit
Prípojka 2	metrický vonkajší závit valcový
Tvar tesnenia 2	Vnútorý kužeľ 24°
Konštrukcia	Nákrutka pre naskrutkovanie
Vyhotovenie	priame
Norma	DIN 2353 ISO 8434-1
Rozsah dodávky	Hrdlo s presuvnou maticou a zárezným krúžkom
Materiál	Oceľ
Povrchová ochrana	galvanický povlak

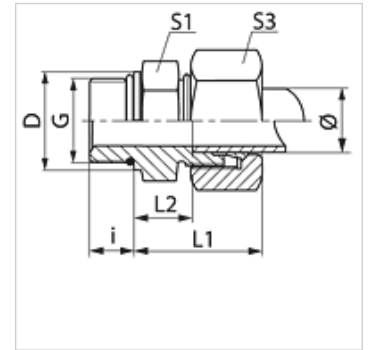

Poznámka

Pokyny pre montáž, zabudovanie, tlakové zaťaženie a povolené prevádzkové teploty nájdete v technických informáciách pre fittingové nákrutky

Výrobok

Označenie	Konštrukčný rad	Prevádzkový tlak	Rúrka, vonkajší Ø G (mm)	D: (mm)	i (mm)	L1 (mm)	L2 (mm)	S1	S3	OR	
VU NW 04 HL 7/16	D	PN 315	6	7/16" -20 UNF	17,0	9	23,0	8,5	14	16	8,92 x 1,83
VU NW 04 HL 1/2	D	PN 315	6	1/2" -20 UNF	17,0	9	23,0	8,5	17	17	10,52 x 1,83
VU NW 04 HL 9/16	D	PN 315	6	9/16" -18 UNF	17,6	10	35,0	10,0	19	14	11,90 x 1,98
VU NW 06 HL 7/16	D	PN 315	8	7/16" -20 UNF	14,4	9	28,0	13,0	17	17	8,92 x 1,83
VU NW 06 HL 1/2	D	PN 315	8	1/2" -20 UNF	17,0	9	25,0	10,0	17	17	10,52 x 1,83
VU NW 06 HL 9/16	D	PN 315	8	9/16" -18 UNF	19,0	10	25,0	10,0	17	17	11,90 x 1,98
VU NW 08 HL 7/16	D	PN 315	10	7/16" -20 UNF	14,4	9	29,0	14,0	17	19	8,92 x 1,83
VU NW 08 HL 9/16	D	PN 315	10	9/16" -18 UNF	19,0	10	26,0	11,0	19	19	16,36 x 2,20
VU NW 08 HL 3/4	D	PN 315	10	3/4" -16 UNF	22,3	11	26,0	11,0	24	19	16,36 x 2,20
VU NW 10 HL 9/16	D	PN 315	12	9/16" -18 UNF	17,6	10	27,0	12,0	19	22	11,90 x 1,98
VU NW 10 HL 3/4	D	PN 315	12	3/4" -16 UNF	22,3	11	28,0	13,0	24	22	16,36 x 2,20
VU NW 10 HL 7/8	D	PN 315	12	7/8" -14 UNF	25,5	13	29,0	14,0	27	22	19,18 x 2,46
VU NW 13 HL 9/16	D	PN 315	15	9/16" -18 UNF	17,6	10	29,0	14,0	27	27	11,90 x 1,98
VU NW 13 HL 3/4	D	PN 315	15	3/4" -16 UNF	22,3	11	29,0	14,0	24	27	16,36 x 2,20
VU NW 13 HL 7/8	D	PN 315	15	7/8" -14 UNF	25,5	13	30,5	15,5	27	27	19,18 x 2,46
VU NW 16 HL 3/4	D	PN 315	18	3/4" -16 UNF	22,3	11	29,5	14,5	27	32	16,36 x 2,20
VU NW 16 HL 7/8	D	PN 315	18	7/8" -14 UNF	25,5	13	29,5	14,5	27	32	19,18 x 2,46
VU NW 16 HL 1 1/16	D	PN 315	18	1.1/16" -12 UN	31,9	15	29,5	14,5	32	32	23,47 x 2,95
VU NW 20 HL 7/8	D	PN 160	22	7/8" -14 UNF	25,5	13	33,0	16,5	32	36	19,18 x 2,46
VU NW 20 HL 1 1/16	D	PN 160	22	1.1/16" -12 UN	31,9	15	33,0	16,5	32	36	23,47 x 2,95
VU NW 20 HL 1 5/16	D	PN 160	22	1.5/16" -12 UN	38,2	15	34,0	17,5	41	36	29,74 x 2,95
VU NW 25 HL 7/8	D	PN 160	22	7/8" -14 UNF	25,5	14	34,0	17,5	32	41	19,18 x 2,46
VU NW 25 HL 1 1/16	D	PN 160	28	1.1/16" -12 UN	31,9	15	34,0	17,5	41	41	23,47 x 2,95
VU NW 25 HL 1 5/16	D	PN 160	28	1.5/16" -12 UN	38,2	15	34,0	17,5	41	41	29,74 x 2,95
VU NW 32 HL 1 5/16	D	PN 160	35	1.5/16" -12 UN	38,2	15	39,0	17,5	50	46	29,74 x 2,95
VU NW 32 HL 1 5/8	D	PN 160	35	1.5/8" -12 UN	50,0	15	39,0	17,5	50	48	37,47 x 3,00
VU NW 40 HL 1 5/8	D	PN 160	42	1.5/8" -12 UN	55,0	15	42,0	19,0	60	48	37,47 x 3,00
VU NW 40 HL 1 7/8	D	PN 160	42	1.7/8" -12 UN	55,0	15	42,0	19,0	60	55	43,69 x 3,00
VU NW 03 HS 7/16	S	PN 630	6	7/16" -20 UNF	17,0	9	30,0	15,0	17	16	8,92 x 1,83
VU NW 04 HS 7/16	S	PN 630	8	7/16" -20 UNF	14,4	9	30,0	15,0	17	19	8,92 x 1,83
VU NW 04 HS 1/2	S	PN 630	8	1/2" -20 UNF	17,0	9	30,0	15,0	19	17	10,52 x 1,83
VU NW 04 HS 9/16	S	PN 630	8	9/16" -18 UNF	17,6	10	30,0	15,0	19	17	11,90 x 1,98
VU NW 06 HS 9/16	S	PN 630	10	9/16" -18 UNF	17,6	10	31,0	14,5	19	22	11,90 x 1,98
VU NW 06 HS 3/4	S	PN 630	10	3/4" -16 UNF	22,3	11	31,0	14,5	24	22	16,36 x 2,20
VU NW 08 HS 9/16	S	PN 630	12	9/16" -18 UNF	17,6	10	31,0	14,5	22	24	11,90 x 1,98
VU NW 08 HS 3/4	S	PN 630	12	3/4" -16 UNF	22,3	11	34,0	17,5	24	24	16,36 x 2,20
VU NW 08 HS 7/8	S	PN 630	12	7/8" -14 UNF	25,5	13	37,0	18,5	27	24	19,18 x 2,46
VU NW 10 HS 3/4	S	PN 630	14	3/4" -16 UNF	22,3	11	34,0	16,0	27	24	16,36 x 2,20
VU NW 13 HS 3/4	S	PN 400	16	3/4" -16 UNF	22,3	11	34,0	15,5	24	30	16,36 x 2,20
VU NW 13 HS 7/8	S	PN 400	16	7/8" -14 UNF	25,5	13	37,0	18,5	27	30	19,18 x 2,46
VU NW 13 HS 1 1/16	S	PN 400	16	1.1/16" -12 UN	31,9	15	37,0	18,5	32	30	23,47 x 2,95



Výrobok

Označenie	Konštrukčný rad	Prevádzkový tlak	Rúrka, vonkajší Ø G (mm)	D: (mm)	i (mm)	L1 (mm)	L2 (mm)	S1	S3	OR	
VU NW 16 HS 3/4	S	PN 400	20	3/4" -16 UNF	22,3	11	42,0	20,5	32	36	16,36 x 2,20
VU NW 16 HS 7/8	S	PN 400	20	7/8" -14 UNF	25,5	13	42,0	20,5	32	36	19,18 x 2,46
VU NW 16 HS 1 1/16	S	PN 400	20	1.1/16" -12 UN	31,9	15	42,0	20,5	32	36	23,47 x 2,95
VU NW 20 HS 1 1/16	S	PN 400	25	1.1/16" -12 UN	31,9	15	47,0	23,0	41	46	23,47 x 2,95
VU NW 20 HS 1 5/16	S	PN 400	25	1,5/16" -12 UN	38,2	15	47,0	23,0	41	46	29,74 x 2,95
VU NW 25 HS 1 5/16	S	PN 400	30	1,5/16" -12 UN	38,2	15	50,0	23,5	46	50	29,74 x 2,95
VU NW 25 HS 1 5/8	S	PN 400	30	1,5/8" -12 UN	47,7	15	50,0	23,5	50	50	37,47 x 3,00
VU NW 32 HS 1 5/8	S	PN 315	38	1,5/8" -12 UN	54,0	15	42,0	19,0	55	60	37,47 x 3,00
VU NW 32 HS 1 7/8	S	PN 315	38	1,7/8" -12 UN	55,0	15	57,0	26,0	60	55	43,69 x 3,00

Konštrukčný rad: LL = Veľmi ľahká L = Ľahká S = Ťažká - PN = Menovitý tlak PB = Max. prevádzkový tlak - Ø = Vonkajší priemer rúrky

Varianty produktu

VU VA	Nákrutka pre naskrutkovanie, Ušľachtilá oceľ
XVU	Nákrutka pre naskrutkovanie, Oceľ