

XNAH VA

Redukčná nákrutka, nepredmontovaná

HANSA FLEX

Vlastnosti

Prípojka 1	Nátrubky nepredmontované
Tvar tesnenia 1	Pripojenie so zárezným krúžkom
Prípojka 2	metrický vonkajší závit valcový
Tvar tesnenia 2	Vnútorný kužeľ 24°
Konštrukcia	Redukčná nákrutka, nepredmontovaná
Vyhotovenie	priame
Rozsah dodávky	Hrdlo (bez presuvnej matice a zárezného krúžku)
Materiál	Ušľachtilá oceľ

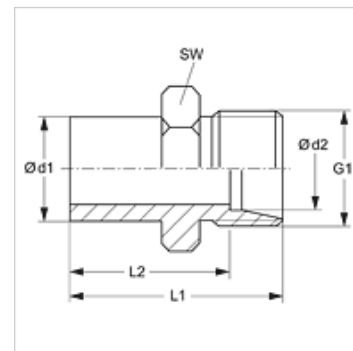

Poznámka

Pokyny pre montáž, zabudovanie, tlakové zaťaženie a povolené prevádzkové teploty nájdete v technických informáciách pre fittingové nákrutky

Výrobok

Označenie	Konštrukčný rad	Prevádzkový tlak	Ø d1 (mm)	Ø d2 (mm)	G1	L1 (mm)	L2 (mm)	SW (mm)
XNAH NW 06 L 04 VA	D	PN 315	8	6	M 12 x 1,5	33,5	26,5	12
XNAH NW 08 L 04 VA	D	PN 315	10	6	M 12 x 1,5	34,0	27,0	12
XNAH NW 08 L 06 VA	D	PN 315	10	8	M 14 x 1,5	34,5	27,5	14
XNAH NW 10 L 04 VA	D	PN 315	12	6	M 12 x 1,5	35,0	28,0	14
XNAH NW 10 L 06 VA	D	PN 315	12	8	M 14 x 1,5	36,0	29,0	14
XNAH NW 10 L 08 VA	D	PN 315	12	10	M 16 x 1,5	37,0	30,0	17
XNAH NW 13 L 04 VA	D	PN 315	15	6	M 12 x 1,5	36,0	29,0	17
XNAH NW 13 L 06 VA	D	PN 315	15	8	M 14 x 1,5	36,0	29,0	17
XNAH NW 13 L 08 VA	D	PN 315	15	10	M 16 x 1,5	37,0	30,0	17
XNAH NW 13 L 10 VA	D	PN 315	15	12	M 18 x 1,5	38,0	31,0	19
XNAH NW 16 L 04 VA	D	PN 315	18	6	M 12 x 1,5	37,0	30,0	19
XNAH NW 16 L 06 VA	D	PN 315	18	8	M 14 x 1,5	38,0	31,0	19
XNAH NW 16 L 08 VA	D	PN 315	18	10	M 16 x 1,5	39,0	32,0	19
XNAH NW 16 L 10 VA	D	PN 315	18	12	M 18 x 1,5	40,0	33,0	19
XNAH NW 16 L 13 VA	D	PN 315	18	15	M 22 x 1,5	39,5	32,5	24
XNAH NW 20 L 04 VA	D	PN 160	22	6	M 12 x 1,5	39,0	32,0	27
XNAH NW 20 L 06 VA	D	PN 160	22	8	M 14 x 1,5	40,0	33,0	24
XNAH NW 20 L 08 VA	D	PN 160	22	10	M 16 x 1,5	42,0	35,0	24
XNAH NW 20 L 10 VA	D	PN 160	22	12	M 18 x 1,5	42,0	35,0	24
XNAH NW 20 L 13 VA	D	PN 160	22	15	M 22 x 1,5	43,0	36,0	24
XNAH NW 20 L 16 VA	D	PN 160	22	18	M 26 x 1,5	44,0	36,5	27
XNAH NW 25 L 04 VA	D	PN 160	28	6	M 12 x 1,5	41,0	34,0	30
XNAH NW 25 L 06 VA	D	PN 160	28	8	M 14 x 1,5	41,0	34,0	30
XNAH NW 25 L 08 VA	D	PN 160	28	10	M 16 x 1,5	42,0	35,0	30
XNAH NW 25 L 10 VA	D	PN 160	28	12	M 18 x 1,5	43,0	36,0	30
XNAH NW 25 L 13 VA	D	PN 160	28	15	M 22 x 1,5	44,0	37,0	30
XNAH NW 25 L 16 VA	D	PN 160	28	18	M 26 x 1,5	45,0	37,5	30
XNAH NW 25 L 20 VA	D	PN 160	28	22	M 30 x 2	47,0	39,5	32
XNAH NW 32 L 04 VA	D	PN 160	35	6	M 12 x 1,5	47,0	40,0	36
XNAH NW 32 L 06 VA	D	PN 160	35	8	M 14 x 1,5	47,0	40,0	36
XNAH NW 32 L 08 VA	D	PN 160	35	10	M 16 x 1,5	48,0	41,0	36
XNAH NW 32 L 10 VA	D	PN 160	35	12	M 18 x 1,5	49,0	42,0	36
XNAH NW 32 L 13 VA	D	PN 160	35	15	M 22 x 1,5	50,0	43,0	36
XNAH NW 32 L 16 VA	D	PN 160	35	18	M 26 x 1,5	49,5	42,0	36
XNAH NW 32 L 20 VA	D	PN 160	35	22	M 30 x 2	53,0	45,5	36
XNAH NW 32 L 25 VA	D	PN 160	35	28	M 36 x 2	54,0	46,5	41
XNAH NW 40 L 08 VA	D	PN 160	42	10	M 16 x 1,5	49,0	42,0	46
XNAH NW 40 L 10 VA	D	PN 160	42	12	M 18 x 1,5	50,0	43,0	46
XNAH NW 40 L 13 VA	D	PN 160	42	15	M 22 x 1,5	52,0	45,0	46
XNAH NW 40 L 16 VA	D	PN 160	42	18	M 26 x 1,5	51,5	44,0	46
XNAH NW 40 L 20 VA	D	PN 160	42	22	M 30 x 2	53,5	46,0	46
XNAH NW 40 L 25 VA	D	PN 160	42	28	M 36 x 2	55,0	47,5	46
XNAH NW 40 L 32 VA	D	PN 160	42	35	M 45 x 2	58,0	47,5	46
XNAH NW 04 S 03 VA	S	PN 630	8	6	M 14 x 1,5	37,0	30,0	14



Napriek čo najstarostlivejšej kontrole nemôžeme vylúčiť chyby a nepreberáme žiadnu záruku za zahrnuté údaje.

06.02.2025

HANSA-FLEX AG

www.hansa-flex.com

1

Výrobok

Označenie	Konštrukčný rad	Prevádzkový tlak	Ø d1 (mm)	Ø d2 (mm)	G1	L1 (mm)	L2 (mm)	SW (mm)
XNAH NW 06 S 03 VA	S	PN 630	10	6	M 14 x 1,5	39,0	32,0	14
XNAH NW 06 S 04 VA	S	PN 630	10	8	M 16 x 1,5	41,0	34,0	17
XNAH NW 08 S 03 VA	S	PN 630	12	6	M 14 x 1,5	39,0	32,0	14
XNAH NW 08 S 04 VA	S	PN 630	12	8	M 16 x 1,5	41,0	34,0	17
XNAH NW 08 S 06 VA	S	PN 630	12	10	M 18 x 1,5	41,0	33,5	19
XNAH NW 10 S 03 VA	S	PN 630	14	6	M 14 x 1,5	42,0	35,0	17
XNAH NW 10 S 04 VA	S	PN 630	14	8	M 16 x 1,5	44,0	37,0	17
XNAH NW 10 S 06 VA	S	PN 630	14	10	M 18 x 1,5	44,0	36,5	19
XNAH NW 10 S 08 VA	S	PN 630	14	12	M 20 x 1,5	46,0	38,5	22
XNAH NW 13 S 03 VA	S	PN 630	16	6	M 14 x 1,5	42,0	35,0	17
XNAH NW 13 S 04 VA	S	PN 630	16	8	M 16 x 1,5	44,0	37,0	17
XNAH NW 13 S 06 VA	S	PN 630	16	10	M 18 x 1,5	44,0	36,5	19
XNAH NW 13 S 08 VA	S	PN 630	16	12	M 20 x 1,5	46,0	38,5	22
XNAH NW 13 S 10 VA	S	PN 630	16	14	M 22 x 1,5	48,0	40,0	24
XNAH NW 16 S 03 VA	S	PN 400	20	6	M 14 x 1,5	49,0	42,0	22
XNAH NW 16 S 04 VA	S	PN 400	20	8	M 16 x 1,5	49,0	42,0	22
XNAH NW 16 S 06 VA	S	PN 400	20	10	M 18 x 1,5	50,0	42,5	22
XNAH NW 16 S 08 VA	S	PN 400	20	12	M 20 x 1,5	51,0	43,5	22
XNAH NW 16 S 10 VA	S	PN 400	20	14	M 22 x 1,5	53,0	45,0	24
XNAH NW 16 S 13 VA	S	PN 400	20	16	M 24 x 1,5	53,0	44,5	27
XNAH NW 20 S 03 VA	S	PN 400	25	6	M 14 x 1,5	51,0	44,0	27
XNAH NW 20 S 04 VA	S	PN 400	25	8	M 16 x 1,5	51,0	44,0	27
XNAH NW 20 S 06 VA	S	PN 400	25	10	M 18 x 1,5	51,0	43,5	27
XNAH NW 20 S 08 VA	S	PN 400	25	12	M 20 x 1,5	53,0	45,5	27
XNAH NW 20 S 10 VA	S	PN 400	25	14	M 22 x 1,5	55,0	47,0	27
XNAH NW 20 S 13 VA	S	PN 400	25	16	M 24 x 1,5	56,0	45,5	27
XNAH NW 20 S 16 VA	S	PN 400	25	20	M 30 x 2	49,0	48,5	32
XNAH NW 25 S 03 VA	S	PN 400	30	6	M 14 x 1,5	59,0	52,0	32
XNAH NW 25 S 04 VA	S	PN 400	30	8	M 16 x 1,5	59,0	52,0	32
XNAH NW 25 S 06 VA	S	PN 400	30	10	M 18 x 1,5	59,0	51,5	32
XNAH NW 25 S 08 VA	S	PN 400	30	12	M 20 x 1,5	59,0	51,5	32
XNAH NW 25 S 10 VA	S	PN 400	30	14	M 22 x 1,5	58,0	50,0	32
XNAH NW 25 S 13 VA	S	PN 400	30	16	M 24 x 1,5	61,0	52,5	32
XNAH NW 25 S 16 VA	S	PN 400	30	20	M 30 x 2	60,0	49,5	32
XNAH NW 25 S 20 VA	S	PN 400	30	25	M 36 x 2	69,0	57,0	41
XNAH NW 32 S 03 VA	S	PN 315	38	6	M 14 x 1,5	62,0	55,0	41
XNAH NW 32 S 04 VA	S	PN 315	38	8	M 16 x 1,5	62,0	55,0	41
XNAH NW 32 S 06 VA	S	PN 315	38	10	M 18 x 1,5	62,0	54,5	41
XNAH NW 32 S 08 VA	S	PN 315	38	12	M 20 x 1,5	62,0	54,5	41
XNAH NW 32 S 10 VA	S	PN 315	38	14	M 22 x 1,5	65,0	57,0	41
XNAH NW 32 S 13 VA	S	PN 315	38	16	M 24 x 1,5	64,0	55,5	41
XNAH NW 32 S 16 VA	S	PN 315	38	20	M 30 x 2	67,0	56,5	41
XNAH NW 32 S 20 VA	S	PN 315	38	25	M 36 x 2	72,0	60,0	41
XNAH NW 32 S 25 VA	S	PN 315	38	30	M 42 x 2	74,0	60,5	46

Konštrukčný rad: LL = Veľmi ľahká L = Ľahká S = Ťažká – PN = Menovitý tlak PB = Max. prevádzkový tlak – Ø d1 = Vonkajší priemer rúry – Ø d2 = Vonkajší priemer rúry

Varianty produktu

XNAH	Redukčná nákrutka, nepredmontovaná, Oceľ
NAH VA	Redukčná nákrutka, nepredmontovaná, Ušľachtilá oceľ

Prídavné elementy

VOM	Predmontované hrdlá
-----	---------------------