

Vlastnosti

Prípojka 1	Vonkajší závit BSP, valcový
Tvar tesnenia 1	Tvar E
Prípojka 2	metrický vonkajší závit valcový
Tvar tesnenia 2	Vnútny kužeľ 24°
Konštrukcia	Priehradková nákrutka k naskrutkovaniu
Vyhotovenie	priame
Norma	DIN 2353 ISO 8434-1
Rozsah dodávky	Hrdlo (bez presuvnej matice a zárezného krúžku)
Materiál	Oceľ
Povrchová ochrana	galvanický povlak

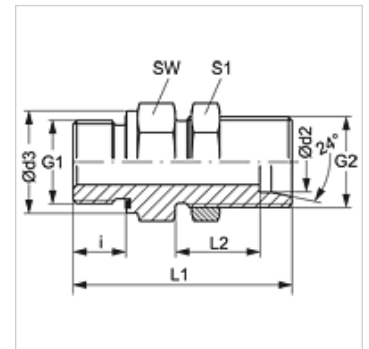

Poznámka

Pokyny pre montáž, zabudovanie, tlakové zaťaženie a povolené prevádzkové teploty nájdete v technických informáciách pre fittingové nákrutky

Výrobok

Označenie	Konštrukčný rad	Prevádzkový tlak	Ø d2 (mm)	G1	G2	Ø d3 (mm)	i (mm)	L1 (mm)	L2 (mm)	SW (mm)	S1
XSVR NW 06 HL ED	D	PN 315	8	G 1/4" -19	M 14 x 1,5	18,9	12	53,0	27,0	19	19
XSVR NW 06 HL 3/8 ED	D	PN 315	8	G 3/8" -19	M 14 x 1,5	21,9	12	54,5	27,0	22	19
XSVR NW 06 HL 1/2 ED	D	PN 315	8	G 1/2" -14	M 14 x 1,5	26,9	14	58,0	27,0	27	19
XSVR NW 08 HL ED	D	PN 315	10	G 1/4" -19	M 16 x 1,5	18,9	12	55,0	28,0	22	22
XSVR NW 08 HL 1/2 ED	D	PN 315	10	G 1/2" -14	M 16 x 1,5	26,9	14	59,0	27,0	27	22
XSVR NW 10 HL ED	D	PN 315	12	G 3/8" -19	M 18 x 1,5	21,9	12	56,5	29,0	24	24
XSVR NW 10 HL 1/2 ED	D	PN 315	12	G 1/2" -14	M 18 x 1,5	26,9	14	60,0	29,0	27	24
XSVR NW 13 HL ED	D	PN 250	15	G 1/2" -14	M 22 x 1,5	26,9	14	62,0	31,0	27	30
XSVR NW 13 HL 3/4 ED	D	PN 250	15	G 3/4" -14	M 22 x 1,5	31,9	16	66,0	31,0	32	30
XSVR NW 16 HL ED	D	PN 250	18	G 1/2" -14	M 26 x 1,5	26,9	14	66,0	33,5	32	36
XSVR NW 16 HL 3/4 ED	D	PN 250	18	G 3/4" -14	M 26 x 1,5	31,9	16	68,0	33,5	32	36
XSVR NW 16 HL 1 ED	D	PN 250	18	G 1" -11	M 26 x 1,5	39,9	18	73,0	33,5	41	36
XSVR NW 20 HL ED	D	PN 250	22	G 3/4" -14	M 30 x 2	31,9	16	71,0	34,5	36	41
XSVR NW 40 HL ED	D	PN 250	42	G 1,1/2" -11	M 52 x 2	54,9	22	86,0	36,0	60	65
XSVR NW 08 HS 1/2 ED	S	PN 400	12	G 1/2" -14	M 20 x 1,5	26,9	14	65,0	30,5	27	27
XSVR NW 13 HS ED	S	PN 400	16	G 1/2" -14	M 24 x 1,5	26,9	14	68,0	31,5	32	32
XSVR NW 13 HS 3/4 ED	S	PN 400	16	G 3/4" -14	M 24 x 1,5	31,9	16	70,0	31,5	32	32
XSVR NW 16 HS ED	S	PN 400	20	G 3/4" -14	M 30 x 2	31,9	16	75,0	33,5	41	41
XSVR NW 20 HS 3/4 ED	S	PN 400	25	G 3/4" -14	M 36 x 2	31,9	16	80,0	35,0	46	46
XSVR NW 20 HS ED	S	PN 400	25	G 1" -11	M 36 x 2	39,9	18	82,0	35,0	46	46
XSVR NW 25 HS ED	S	PN 400	30	G 1,1/4" -11	M 42 x 2	49,9	20	89,0	37,5	50	50

Konštrukčný rad: LL = Veľmi ľahká L = Ľahká S = Ťažká - PN = Menovitý tlak PB = Max. prevádzkový tlak - Ø d2 = Vonkajší priemer rúry

Náhradné diely

WD	Mäkké tesnenie pre nákrutky ED
-----------	--------------------------------