

# LOET DK AJF

Nátrubok DK AJF

**HANSA FLEX**

## Vlastnosti

**Konštrukcia** Hrdlo k spájkovaniu

**Vyhotovenie** priame

**Materiál** Oceľ

**Povrchová ochrana** olejom

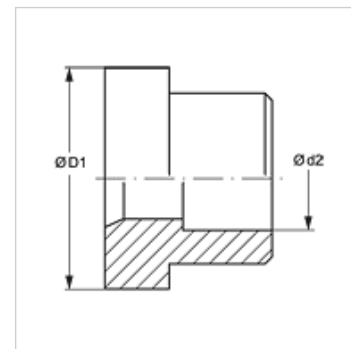

## Výrobok

Označenie	Ø d2 (mm)	Ø D1 (mm)	L1 (mm)
LOET 04 DK 06 AJF	6	16,0	9,5
LOET 06 DK 08 AJF	8	16,0	9,5
LOET 06 DK 10 AJF	10	16,0	9,5
LOET 08 DK 12 AJF	12	19,0	9,5
LOET 10 DK 14 AJF	14	23,0	10,5
LOET 10 DK 15 AJF	15	23,0	10,5
LOET 10 DK 16 AJF	16	23,0	10,5
LOET 12 DK 18 AJF	18	28,0	14,0
LOET 12 DK 20 AJF	20	28,0	14,0
LOET 16 DK 22 AJF	22	34,0	15,5
LOET 16 DK 25 AJF	25	34,0	15,5
LOET 20 DK 28 AJF	28	41,0	15,5
LOET 20 DK 30 AJF	30	41,0	15,5
LOET 20 DK 32 AJF	32	41,0	15,5
LOET 24 DK 35 AJF	35	49,0	15,5
LOET 24 DK 38 AJF	38	49,0	15,5

Ø d2 = Vonkajší priemer rúry