

### Vlastnosti

<b>Prípojka 1</b>	metrický vonkajší závit valcový
<b>Tvar tesnenia 1</b>	Tvar B
<b>Prípojka 2</b>	metrický vonkajší závit valcový
<b>Tvar tesnenia 2</b>	Vnútorný kužeľ 24°
<b>Konštrukcia</b>	Nákrutka pre naskrutkovanie
<b>Vyhotovenie</b>	priame
<b>Norma</b>	DIN 2353 ISO 8434-1
<b>Rozsah dodávky</b>	Hrdlo (bez presuvnej matice a zárezného krúžku)
<b>Materiál</b>	Oceľ
<b>Povrchová ochrana</b>	galvanický povlak

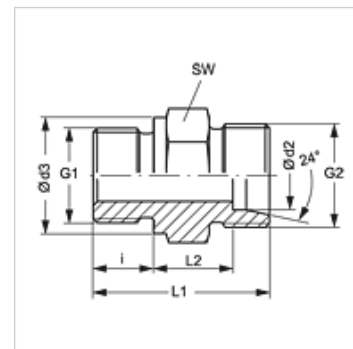

### Poznámka

Pokyny pre montáž, zabudovanie, tlakové zaťaženie a povolené prevádzkové teploty nájdete v technických informáciách pre fittingové nákrutky

### Výrobok

Označenie	Konštrukčný rad	Prevádzkový tlak	Ø d2 (mm)	G1	G2	Ø d3 (mm)	i (mm)	L1 (mm)	L2 (mm)	SW (mm)
XVM 16 LL	LL	PN 100	16	M 22 x 1,5	M 22 x 1,5	27	14	36,5	15,5	27
XVM 16 LL 18-1.5	LL	PN 100	16	M 18 x 1,5	M 22 x 1,5	23	12	33,5	14,5	24
XVM NW 04 HL	D	PN 315	6	M 10 x 1	M 12 x 1,5	14	8	23,5	8,5	14
XVM NW 04 HL 12	D	PN 315	6	M 12 x 1,5	M 12 x 1,5	17	12	28,0	9,0	17
XVM NW 04 HL 14	D	PN 315	6	M 14 x 1,5	M 12 x 1,5	19	12	28,0	9,0	19
XVM NW 04 HL 16	D	PN 315	6	M 16 x 1,5	M 12 x 1,5	21	12	28,0	9,0	22
XVM NW 04 HL 18	D	PN 315	6	M 18 x 1,5	M 12 x 1,5	23	12	28,5	9,5	24
XVM NW 04 HL 22	D	PN 315	6	M 22 x 1,5	M 12 x 1,5	27	14	31,0	10,0	27
XVM NW 06 HL	D	PN 315	8	M 12 x 1,5	M 14 x 1,5	17	12	29,0	10,0	17
XVM NW 06 HL 10	D	PN 315	8	M 10 x 1	M 14 x 1,5	14	8	24,5	9,5	17
XVM NW 06 HL 14	D	PN 315	8	M 14 x 1,5	M 14 x 1,5	19	12	29,0	10,0	19
XVM NW 06 HL 16	D	PN 315	8	M 16 x 1,5	M 14 x 1,5	21	12	29,0	10,0	22
XVM NW 06 HL 18	D	PN 315	8	M 18 x 1,5	M 14 x 1,5	23	12	29,5	10,5	24
XVM NW 06 HL 22	D	PN 315	8	M 22 x 1,5	M 14 x 1,5	27	14	32,0	11,0	27
XVM NW 08 HL	D	PN 315	10	M 14 x 1,5	M 16 x 1,5	19	12	30,0	11,0	19
XVM NW 08 HL 12	D	PN 315	10	M 12 x 1,5	M 16 x 1,5	17	12	30,0	11,0	17
XVM NW 08 HL 16	D	PN 315	10	M 16 x 1,5	M 16 x 1,5	21	12	30,0	11,0	22
XVM NW 08 HL 18	D	PN 315	10	M 18 x 1,5	M 16 x 1,5	23	12	30,5	11,5	24
XVM NW 08 HL 22	D	PN 315	10	M 22 x 1,5	M 16 x 1,5	27	14	33,0	12,0	27
XVM NW 10 HL	D	PN 315	12	M 16 x 1,5	M 18 x 1,5	21	12	31,5	12,5	22
XVM NW 10 HL 12	D	PN 315	12	M 12 x 1,5	M 18 x 1,5	17	12	31,5	12,5	19
XVM NW 10 HL 14	D	PN 315	12	M 14 x 1,5	M 18 x 1,5	19	12	31,5	12,5	22
XVM NW 10 HL 18	D	PN 315	12	M 18 x 1,5	M 18 x 1,5	23	12	32,0	13,0	24
XVM NW 10 HL 22	D	PN 315	12	M 22 x 1,5	M 18 x 1,5	27	14	34,5	13,5	27
XVM NW 10 HL 24	D	PN 315	12	M 24 x 1,5	M 18 x 1,5	29	14	34,5	13,5	32
XVM NW 10 HL 26	D	PN 315	12	M 26 x 1,5	M 18 x 1,5	31	16	36,5	13,5	32
XVM NW 13 HL	D	PN 315	15	M 18 x 1,5	M 22 x 1,5	23	12	32,5	13,5	24
XVM NW 13 HL 14	D	PN 315	15	M 14 x 1,5	M 22 x 1,5	19	12	32,0	13,0	24
XVM NW 13 HL 16	D	PN 315	15	M 16 x 1,5	M 22 x 1,5	21	12	32,0	13,0	24
XVM NW 13 HL 20	D	PN 250	15	M 20 x 1,5	M 22 x 1,5	25	14	34,5	13,5	27
XVM NW 13 HL 22	D	PN 315	15	M 22 x 1,5	M 22 x 1,5	27	14	35,0	14,0	27
XVM NW 13 HL 26	D	PN 315	15	M 26 x 1,5	M 22 x 1,5	31	16	37,0	14,0	32
XVM NW 13 HL 30	D	PN 315	15	M 30 x 2	M 22 x 1,5	36	16	37,0	14,0	41
XVM NW 16 HL	D	PN 315	18	M 22 x 1,5	M 26 x 1,5	27	14	36,0	14,5	27
XVM NW 16 HL 18	D	PN 315	18	M 18 x 1,5	M 26 x 1,5	23	12	33,5	14,0	27
XVM NW 16 HL 26	D	PN 315	18	M 26 x 1,5	M 26 x 1,5	31	16	38,0	14,5	32
XVM NW 16 HL 27	D	PN 315	18	M 27 x 2	M 26 x 1,5	32	16	38,0	14,5	32
XVM NW 16 HL 30-1.5	D	PN 315	18	M 30 x 1,5	M 26 x 1,5	36	16	38,0	14,5	41
XVM NW 20 HL	D	PN 160	22	M 26 x 1,5	M 30 x 2	31	16	40,0	16,5	32
XVM NW 20 HL 18	D	PN 160	22	M 18 x 1,5	M 30 x 2	23	12	35,5	16,0	32
XVM NW 20 HL 22	D	PN 160	22	M 22 x 1,5	M 30 x 2	27	14	38,0	16,5	32



## Výrobok

Označenie	Konštrukčný rad	Prevádzkový tlak	Ø d2 (mm)	G1	G2	Ø d3 (mm)	i (mm)	L1 (mm)	L2 (mm)	SW (mm)
XVM NW 20 HL 22-LS 20	D	PN 160	22	M 22 x 1,5	M 30 x 2	27	14	60,0	38,5	32
XVM NW 20 HL 30-1.5	D	PN 160	22	M 30 x 1,5	M 30 x 2	36	16	40,0	16,5	41
XVM NW 20 HL 33-LS 20	D	PN 160	22	M 33 x 2	M 30 x 2	39	18	62,0	36,5	41
XVM NW 25 HL	D	PN 160	28	M 33 x 2	M 36 x 2	39	18	43,0	17,5	41
XVM NW 25 HL-LS 20	D	PN 160	28	M 33 x 2	M 36 x 2	39	18	60,0	23,5	41
XVM NW 25 HL 22	D	PN 160	28	M 22 x 1,5	M 36 x 2	27	14	39,0	17,5	41
XVM NW 25 HL 26	D	PN 160	28	M 26 x 1,5	M 36 x 2	31	16	41,0	17,5	41
XVM NW 25 HL 27	D	PN 160	28	M 27 x 2	M 36 x 2	32	16	41,0	17,5	41
XVM NW 25 HL 42	D	PN 160	28	M 42 x 2	M 36 x 2	49	22	45,0	17,5	50
XVM NW 32 HL	D	PN 160	35	M 42 x 2	M 45 x 2	49	20	48,0	17,5	50
XVM NW 40 HL	D	PN 160	42	M 48 x 2	M 52 x 2	55	22	52,0	19,0	55
XVM NW 03 HS	S	PN 400	6	M 12 x 1,5	M 14 x 1,5	17	12	32,0	13,0	17
XVM NW 03 HS 16	S	PN 400	6	M 16 x 1,5	M 14 x 1,5	21	12	32,0	13,0	22
XVM NW 03 HS 18	S	PN 400	6	M 18 x 1,5	M 14 x 1,5	23	12	32,5	13,5	24
XVM NW 03 HS 22	S	PN 400	6	M 22 x 1,5	M 14 x 1,5	27	14	35,0	14,0	27
XVM NW 04 HS	S	PN 400	8	M 14 x 1,5	M 16 x 1,5	19	12	34,0	15,0	19
XVM NW 06 HS	S	PN 400	10	M 16 x 1,5	M 18 x 1,5	21	12	34,5	15,0	22
XVM NW 06 HS 18	S	PN 400	10	M 18 x 1,5	M 18 x 1,5	23	12	35,0	15,5	24
XVM NW 06 HS 22	S	PN 400	10	M 22 x 1,5	M 18 x 1,5	27	14	37,5	16,0	27
XVM NW 08 HS	S	PN 400	12	M 18 x 1,5	M 20 x 1,5	23	12	36,5	17,0	24
XVM NW 08 HS 14	S	PN 400	12	M 14 x 1,5	M 20 x 1,5	19	12	36,0	16,5	22
XVM NW 08 HS 16	S	PN 400	12	M 16 x 1,5	M 20 x 1,5	21	12	36,0	16,5	22
XVM NW 08 HS 22	S	PN 400	12	M 22 x 1,5	M 20 x 1,5	27	14	39,0	17,5	27
XVM NW 10 HS	S	PN 400	14	M 20 x 1,5	M 22 x 1,5	25	14	41,0	19,0	27
XVM NW 10 HS 16	S	PN 400	14	M 16 x 1,5	M 22 x 1,5	21	12	38,5	18,5	24
XVM NW 10 HS 18	S	PN 400	14	M 18 x 1,5	M 22 x 1,5	23	12	39,0	19,0	24
XVM NW 10 HS 22	S	PN 400	14	M 22 x 1,5	M 22 x 1,5	27	14	41,5	19,5	27
XVM NW 13 HS	S	PN 400	16	M 22 x 1,5	M 24 x 1,5	27	14	41,0	18,5	27
XVM NW 13 HS 16	S	PN 400	16	M 16 x 1,5	M 24 x 1,5	21	12	38,0	17,5	27
XVM NW 13 HS 18	S	PN 400	16	M 18 x 1,5	M 24 x 1,5	23	12	38,5	18,0	27
XVM NW 13 HS 26	S	PN 400	16	M 26 x 1,5	M 24 x 1,5	31	16	43,0	18,5	32
XVM NW 16 HS	S	PN 400	20	M 27 x 2	M 30 x 2	32	16	47,0	20,5	32
XVM NW 16 HS 22	S	PN 400	20	M 22 x 1,5	M 30 x 2	27	14	45,0	20,5	32
XVM NW 16 HS 26	S	PN 400	20	M 26 x 1,5	M 30 x 2	32	16	47,0	20,5	32
XVM NW 16 HS 30-1.5	S	PN 400	20	M 30 x 1,5	M 30 x 2	36	16	47,0	20,5	36
XVM NW 20 HS	S	PN 250	25	M 33 x 2	M 36 x 2	39	18	53,0	23,0	41
XVM NW 20 HS 26	S	PN 250	25	M 26 x 1,5	M 36 x 2	32	16	49,0	20,0	41
XVM NW 20 HS 27	S	PN 250	25	M 27 x 2	M 36 x 2	32	16	51,0	23,0	41
XVM NW 20 HS 30-1.5	S	PN 250	25	M 30 x 1,5	M 36 x 2	36	16	51,0	23,0	41
XVM NW 25 HS	S	PN 160	30	M 42 x 2	M 42 x 2	49	20	57,0	23,5	50
XVM NW 25 HS 30-1.5	S	PN 160	30	M 30 x 1,5	M 42 x 2	36	16	53,0	23,5	50
XVM NW 25 HS 38-1.5	S	PN 160	30	M 38 x 1,5	M 42 x 2	44	16	49,0	19,5	46
XVM NW 32 HS	S	PN 160	38	M 48 x 2	M 52 x 2	55	22	64,0	26,0	55
XVM NW 32 HS 38-1.5	S	PN 160	38	M 38 x 1,5	M 52 x 2	49	20	58,0	26,0	50
XVM NW 32 HS 45-1.5	S	PN 160	38	M 45 x 1,5	M 52 x 2	55	22	58,0	26,0	55

Konštrukčný rad: LL = Veľmi ľahká L = Ľahká S = Ťažká – PN = Menovitý tlak PB = Max. prevádzkový tlak – Ø d2 = Vonkajší priemer rúry

## Varianty produktu

XVM VA	Nákrutka pre naskrutkovanie, Ušľachtilá oceľ
VM	Nákrutka pre naskrutkovanie, Oceľ