

### Vlastnosti

<b>Prípojka 1</b>	metrický vonkajší závit valcový
<b>Tvar tesnenia 1</b>	Tvar E
<b>Prípojka 2</b>	metrický vonkajší závit valcový
<b>Tvar tesnenia 2</b>	Vnútrotný kužeľ 24°
<b>Konštrukcia</b>	Nákrutka pre naskrutkovanie
<b>Vyhotovenie</b>	priame
<b>Norma</b>	DIN 2353 ISO 8434-1
<b>Rozsah dodávky</b>	Hrdlo (bez presuvnej matice a zárezného krúžku)
<b>Materiál</b>	Oceľ
<b>Povrchová ochrana</b>	galvanický povlak

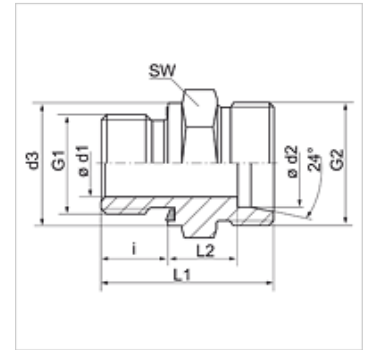

### Poznámka

Pokyny pre montáž, zabudovanie, tlakové zaťaženie a povolené prevádzkové teploty nájdete v technických informáciách pre fittingové nákrutky

### Výrobok

Označenie	Konštrukčný rad	Prevádzkový tlak	Ø d2 (mm)	G1	G2	Ø d3 (mm)	i (mm)	L1 (mm)	L2 (mm)	SW (mm)
XVM NW 04 HL ED	D	PN 315	6	M 10 x 1	M 12 x 1,5	13,9	8	23,5	8,5	14
XVM NW 04 HL 12 ED	D	PN 315	6	M 12 x 1,5	M 12 x 1,5	16,9	12	28,0	9,0	17
XVM NW 06 HL ED	D	PN 315	8	M 12 x 1,5	M 14 x 1,5	16,9	12	29,0	10,0	17
XVM NW 06 HL 14 ED	D	PN 315	8	M 14 x 1,5	M 14 x 1,5	18,9	12	29,0	10,0	19
XVM NW 06 HL 16 ED	D	PN 315	8	M 16 x 1,5	M 14 x 1,5	21,9	12	30,5	11,5	22
XVM NW 06 HL 18 ED	D	PN 315	8	M 18 x 1,5	M 14 x 1,5	23,9	12	30,5	11,5	24
XVM NW 08 HL ED	D	PN 315	10	M 14 x 1,5	M 16 x 1,5	18,9	12	30,0	11,0	19
XVM NW 08 HL 10 ED	D	PN 315	10	M 10 x 1	M 16 x 1,5	-	-	-	-	-
XVM NW 08 HL 12 ED	D	PN 315	10	M 12 x 1,5	M 16 x 1,5	16,9	12	30,0	11,0	19
XVM NW 08 HL 16 ED	D	PN 315	10	M 16 x 1,5	M 16 x 1,5	21,9	12	31,5	12,5	22
XVM NW 08 HL 18 ED	D	PN 315	10	M 18 x 1,5	M 16 x 1,5	23,9	12	31,5	12,5	24
XVM NW 08 HL 22 ED	D	PN 315	10	M 22 x 1,5	M 16 x 1,5	26,9	14	35,0	14,0	27
XVM NW 10 HL ED	D	PN 315	12	M 16 x 1,5	M 18 x 1,5	21,9	12	31,5	12,5	22
XVM NW 10 HL 14 ED	D	PN 315	12	M 14 x 1,5	M 18 x 1,5	18,9	12	31,5	12,5	22
XVM NW 10 HL 18 ED	D	PN 315	12	M 18 x 1,5	M 18 x 1,5	23,9	12	32,0	13,0	24
XVM NW 10 HL 22 ED	D	PN 315	12	M 22 x 1,5	M 18 x 1,5	26,9	14	35,0	14,0	27
XVM NW 13 HL ED	D	PN 315	15	M 18 x 1,5	M 22 x 1,5	23,9	12	32,5	13,5	24
XVM NW 13 HL 16 ED	D	PN 315	15	M 16 x 1,5	M 22 x 1,5	21,9	12	32,0	13,0	24
XVM NW 13 HL 22 ED	D	PN 315	15	M 22 x 1,5	M 22 x 1,5	26,9	14	35,0	14,0	27
XVM NW 16 HL ED	D	PN 315	18	M 22 x 1,5	M 26 x 1,5	26,9	14	36,0	14,5	27
XVM NW 16 HL 18 ED	D	PN 315	18	M 18 x 1,5	M 26 x 1,5	23,9	12	33,5	14,0	27
XVM NW 20 HL ED	D	PN 160	22	M 26 x 1,5	M 30 x 2	31,9	16	40,0	16,5	32
XVM NW 20 HL 22 ED	D	PN 160	22	M 22 x 1,5	M 30 x 2	26,9	14	38,0	16,5	32
XVM NW 25 HL ED	D	PN 160	28	M 33 x 2	M 36 x 2	39,9	18	43,0	17,5	41
XVM NW 32 HL ED	D	PN 160	35	M 42 x 2	M 45 x 2	49,9	20	48,0	17,5	50
XVM NW 40 HL ED	D	PN 160	42	M 48 x 2	M 52 x 2	54,9	22	52,0	19,0	55
XVM NW 03 HS ED	S	PN 630	6	M 12 x 1,5	M 14 x 1,5	16,9	12	32,0	13,0	17
XVM NW 04 HS ED	S	PN 630	8	M 14 x 1,5	M 16 x 1,5	18,9	12	34,0	15,0	19
XVM NW 06 HS ED	S	PN 630	10	M 16 x 1,5	M 18 x 1,5	21,9	12	34,5	15,0	22
XVM NW 08 HS ED	S	PN 630	12	M 18 x 1,5	M 20 x 1,5	23,9	12	36,5	17,0	24
XVM NW 08 HS 22 ED	S	PN 400	12	M 22 x 1,5	M 20 x 1,5	26,9	14	39,0	17,5	27
XVM NW 10 HS ED	S	PN 630	14	M 20 x 1,5	M 22 x 1,5	25,9	14	41,0	19,0	27
XVM NW 13 HS 18 ED	S	PN 400	16	M 18 x 1,5	M 24 x 1,5	23,9	12	38,5	18,0	27
XVM NW 13 HS ED	S	PN 400	16	M 22 x 1,5	M 24 x 1,5	26,9	14	41,0	18,5	27
XVM NW 16 HS ED	S	PN 400	20	M 27 x 2	M 30 x 2	31,9	16	47,0	20,5	32
XVM NW 20 HS ED	S	PN 400	25	M 33 x 2	M 36 x 2	39,9	18	53,0	23,0	41
XVM NW 25 HS ED	S	PN 400	30	M 42 x 2	M 42 x 2	49,9	20	57,0	23,5	50
XVM NW 32 HS ED	S	PN 315	38	M 48 x 2	M 52 x 2	54,9	22	64,0	26,0	55

Konštrukčný rad: LL = Veľmi ľahká L = Ľahká S = Ťažká - PN = Menovitý tlak PB = Max. prevádzkový tlak - Ø d2 = Vonkajší priemer rúry



# XVM ED

Nákrutka pre naskrutkovanie

**HANSA FLEX**

## Variety produktu

XVM ED VA Nákrutka pre naskrutkovanie, Ušľachtilá oceľ

VM ED Nákrutka pre naskrutkovanie, Oceľ

## Náhradné diely

WD Mäkké tesnenie pre nákrutky ED