

## Vlastnosti

Prípojka 1	Vonkajší závit UN/UNF
Tvar tesnenia 1	Tvar F s tesnením na závit
Prípojka 2	metrický vonkajší závit valcový
Tvar tesnenia 2	Vnútny kužeľ 24°
Konštrukcia	Nákrutka pre naskrutkovanie
Vyhotovenie	priame
Norma	DIN 2353 ISO 8434-1
Rozsah dodávky	Hrdlo (bez presuvnej matice a zárezného krúžku)
Materiál	Oceľ
Povrchová ochrana	galvanický povlak

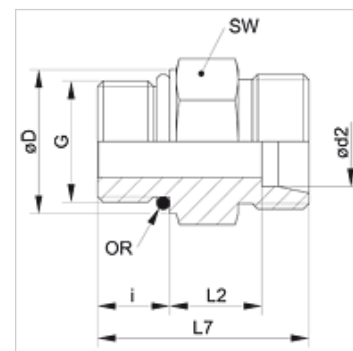

## Poznámka

Pokyny pre montáž, zabudovanie, tlakové zaťaženie a povolené prevádzkové teploty nájdete v technických informáciách pre fittingové nákrutky

## Výrobok

Označenie	Konštrukčný rad	Prevádzkový tlak	Ø d2 (mm)	G	Ø D (mm)	i (mm)	L2 (mm)	L7 (mm)	SW (mm)	OR
XVU NW 04 HL 7/16	D	PN 315	6	7/16" -20 UNF	14,4	9,1	9,9	26,0	17	9,17 x 1,83
XVU NW 04 HL 1/2	D	PN 315	6	1/2" -20 UNF	16,8	9,1	9,9	26,0	17	10,52 x 1,83
XVU NW 04 HL 9/16	D	PN 315	6	9/16" -18 UNF	17,6	10,0	11,0	28,0	19	11,89 x 1,98
XVU NW 06 HL 7/16	D	PN 315	8	7/16" -20 UNF	14,4	9,1	12,9	29,0	17	9,17 x 1,83
XVU NW 06 HL 1/2	D	PN 315	8	1/2" -20 UNF	16,8	9,1	12,9	29,0	17	10,52 x 1,83
XVU NW 06 HL 9/16	D	PN 315	8	9/16" -18 UNF	17,6	10,0	13,0	30,0	19	11,89 x 1,98
XVU NW 08 HL 7/16	D	PN 315	10	7/16" -20 UNF	14,4	9,1	13,9	30,0	17	9,17 x 1,83
XVU NW 08 HL 9/16	D	PN 315	10	9/16" -18 UNF	17,6	10,0	14,0	31,0	19	11,89 x 1,98
XVU NW 08 HL 3/4	D	PN 315	10	3/4" -16 UNF	22,3	11,1	14,9	33,0	24	16,36 x 2,20
XVU NW 10 HL 9/16	D	PN 315	12	9/16" -18 UNF	17,6	10,0	12,0	29,0	19	11,89 x 1,98
XVU NW 10 HL 3/4	D	PN 315	12	3/4" -16 UNF	22,3	11,1	12,9	31,0	24	16,36 x 2,20
XVU NW 10 HL 7/8	D	PN 315	12	7/8" -14 UNF	25,5	12,7	14,3	34,0	27	19,18 x 2,46
XVU NW 13 HL 9/16	D	PN 315	15	9/16" -18 UNF	17,6	10,0	14,0	31,0	24	11,89 x 1,98
XVU NW 13 HL 3/4	D	PN 315	15	3/4" -16 UNF	22,3	11,1	13,9	32,0	24	16,36 x 2,20
XVU NW 13 HL 7/8	D	PN 315	15	7/8" -14 UNF	25,5	12,7	15,8	35,5	27	19,18 x 2,46
XVU NW 16 HL 3/4	D	PN 315	18	3/4" -16 UNF	22,3	11,1	14,4	33,0	27	16,36 x 2,20
XVU NW 16 HL 7/8	D	PN 315	18	7/8" -14 UNF	25,5	12,7	14,5	34,7	27	19,18 x 2,46
XVU NW 16 HL 1 1/16	D	PN 315	18	1.1/16" -12 UN	31,9	15,1	14,4	37,0	32	23,47 x 2,95
XVU NW 20 HL 7/8	D	PN 160	22	7/8" -14 UNF	25,5	12,7	16,8	37,0	32	19,18 x 2,46
XVU NW 20 HL 1 1/16	D	PN 160	22	1.1/16" -12 UN	31,9	15,1	16,4	39,0	32	23,47 x 2,95
XVU NW 20 HL 1 5/16	D	PN 160	22	1.5/16" -12 UN	38,2	15,1	17,4	40,0	41	29,74 x 2,95
XVU NW 25 HL 7/8	D	PN 160	28	7/8" -14 UNF	25,5	12,7	19,8	40,0	41	19,18 x 2,46
XVU NW 25 HL 1 1/16	D	PN 160	28	1.1/16" -12 UN	31,9	15,1	17,4	40,0	41	23,47 x 2,95
XVU NW 25 HL 1 5/16	D	PN 160	28	1.5/16" -12 UN	38,2	15,1	17,4	40,0	41	29,74 x 2,95
XVU NW 32 HL 1 5/16	D	PN 160	35	1.5/16" -12 UN	38,2	15,1	17,4	43,0	46	29,74 x 2,95
XVU NW 32 HL 1 5/8	D	PN 160	35	1.5/8" -12 UN	47,7	15,1	17,4	43,0	50	37,47 x 3,00
XVU NW 40 HL 1 5/8	D	PN 160	42	1.5/8" -12 UN	47,7	15,1	18,9	45,0	55	37,47 x 3,00
XVU NW 40 HL 1 7/8	D	PN 160	42	1.7/8" -12 UN	53,8	15,1	18,9	45,0	60	43,69 x 3,00
XVU NW 03 HS 7/16	S	PN 630	6	7/16" -20 UNF	14,4	9,1	14,9	31,0	17	9,17 x 1,83
XVU NW 04 HS 7/16	S	PN 630	8	7/16" -20 UNF	14,4	9,1	14,9	31,0	17	9,17 x 1,83
XVU NW 04 HS 1/2	S	PN 630	8	1/2" -20 UNF	16,8	9,1	14,9	31,0	19	10,52 x 1,83
XVU NW 04 HS 9/16	S	PN 630	8	9/16" -18 UNF	17,6	10,0	15,0	32,0	19	11,89 x 1,98
XVU NW 06 HS 9/16	S	PN 630	10	9/16" -18 UNF	17,6	10,0	14,5	32,0	19	10,89 x 1,98
XVU NW 06 HS 3/4	S	PN 630	10	3/4" -16 UNF	22,3	11,1	14,4	33,0	24	16,36 x 2,20
XVU NW 08 HS 9/16	S	PN 630	12	9/16" -18 UNF	17,6	10,0	14,5	32,0	22	11,89 x 1,98
XVU NW 08 HS 3/4	S	PN 630	12	3/4" -16 UNF	22,3	11,1	17,4	36,0	24	16,36 x 2,20
XVU NW 08 HS 7/8	S	PN 630	12	7/8" -14 UNF	25,5	12,7	17,8	38,0	27	19,18 x 2,46
XVU NW 10 HS 3/4	S	PN 630	14	3/4" -16 UNF	22,3	11,1	15,9	35,0	24	16,36 x 2,20
XVU NW 13 HS 3/4	S	PN 400	16	3/4" -16 UNF	22,3	11,1	15,4	35,0	24	16,36 x 2,20
XVU NW 13 HS 7/8	S	PN 400	16	7/8" -14 UNF	25,5	12,7	18,8	40,0	27	19,18 x 2,46
XVU NW 13 HS 1 1/16	S	PN 400	16	1.1/16" -12 UN	31,9	15,1	20,4	44,0	32	23,47 x 2,95



## Výrobok

Označenie	Konstruktívny rad	Prevádzkový tlak	Ø d2 (mm)	G	Ø D (mm)	i (mm)	L2 (mm)	L7 (mm)	SW (mm)	OR
XVU NW 16 HS 3/4	S	PN 400	20	3/4" -16 UNF	22,3	11,1	20,4	42,0	32	16,36 x 2,20
XVU NW 16 HS 7/8	S	PN 400	20	7/8" -14 UNF	25,5	12,7	20,8	44,0	32	19,18 x 2,46
XVU NW 16 HS 1 1/16	S	PN 400	20	1.1/16" -12 UN	31,9	15,1	20,4	46,0	32	23,47 x 2,95
XVU NW 20 HS 1 1/16	S	PN 400	25	1.1/16" -12 UN	31,9	15,1	22,9	50,0	41	23,47 x 2,95
XVU NW 20 HS 1 5/16	S	PN 400	25	1,5/16" -12 UN	38,2	15,1	22,9	50,0	41	29,74 x 2,95
XVU NW 25 HS 1 5/16	S	PN 400	30	1,5/16" -12 UN	38,2	15,1	23,4	52,0	46	29,74 x 2,95
XVU NW 25 HS 1 5/8	S	PN 400	30	1,5/8" -12 UN	47,7	15,1	23,4	52,0	50	37,47 x 3,00
XVU NW 32 HS 1 5/8	S	PN 315	38	1,5/8" -12 UN	47,7	15,1	25,9	57,0	55	37,47 x 3,00
XVU NW 32 HS 1 7/8	S	PN 315	38	1,7/8" -12 UN	53,8	15,1	25,9	57,0	60	43,69 x 3,00

Konstruktívny rad: LL = Veľmi ľahká L = Ľahká S = Ťažká – PN = Menovitý tlak PB = Max. prevádzkový tlak – Ø d2 = Vonkajší priemer rúry

## Varianty produktu

XVU VA	Nákrutka pre naskrutkovanie, Ušľachtilá oceľ
VU	Nákrutka pre naskrutkovanie, Oceľ