

W45 HN HJOF

Hrdlo k naskrutkovaniu, uhol 45°

HANSA FLEX

Vlastnosti

Prípojka 1	Vonkajší závit NPT
Tvar tesnenia 1	tesniaci závit
Prípojka 2	Vonkajší závit ORFS
Tvar tesnenia 2	s plochým tesnením s O-kružkom
Konštrukcia	Hrdlo k zaskrutkovaniu
Vyhotovenie	priame
Materiál	Oceľ
Povrchová ochrana	galvanický povlak

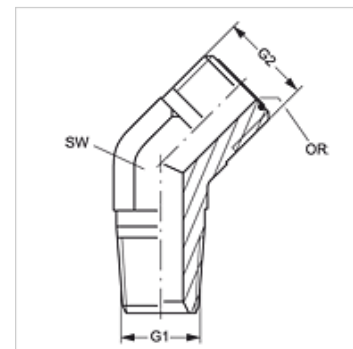

Výrobok

Označenie	G1	G2	SW (mm)	OR
W45 HN 02 HJOF 04	1/8" -27 NPT	9/16" -18 UNF	14	7,65 x 1,78
W45 HN 04 HJOF	1/4" -18 NPT	9/16" -18 UNF	14	7,65 x 1,78
W45 HN 04 HJOF 06	1/4" -18 NPT	11/16" -16 UN	19	9,25 x 1,78
W45 HN 06 HJOF 04	3/8" -18 NPT	9/16" -18 UNF	19	7,65 x 1,78
W45 HN 06 HJOF	3/8" -18 NPT	11/16" -16 UN	19	9,25 x 1,78
W45 HN 06 HJOF 08	3/8" -18 NPT	13/16" -16 UN	19	12,42 x 1,78
W45 HN 08 HJOF 06	1/2" -14 NPT	11/16" -16 UN	22	9,25 x 1,78
W45 HN 08 HJOF	1/2" -14 NPT	13/16" -16 UN	22	12,42 x 1,78
W45 HN 08 HJOF 10	1/2" -14 NPT	1" -14 UNS	27	15,60 x 1,78
W45 HN 12 HJOF	3/4" -14 NPT	1,3/16" -12 UN	30	18,77 x 1,78
W45 HN 16 HJOF	1" -11,5 NPT	1,7/16" -12 UN	37	23,52 x 1,78

SW = Šírka kľúča