

RD IR VA

Spätňý ventil, prípojka

Vlastnosti

Prípojka 1 + 2	Vnútorňý závit BSP, valcový
Tvar tesnenia 1 + 2	Tvar A
Konštrukcia	Spätňý ventil, prípojka
Vyhotovenie	priame
Materiál	Ušľachtilá oceľ

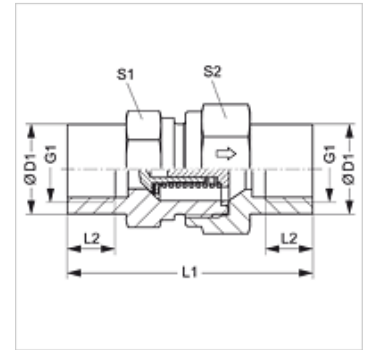

Výrobok

Označenie	Reakčňý tlak	Prevádzkový tlak	G1	Ø D1 (mm)	L1 (mm)	L2 (mm)	S1	S2
RD NW 04 IR VA	pribl. 1 bar	PN 400	G 1/8" -28	19,0	42,5	8,0	19	19
RD NW 06 IR VA	pribl. 1 bar	PN 400	G 1/4" -19	19,0	51,0	12,0	19	19
RD NW 10 IR VA	pribl. 1 bar	PN 400	G 3/8" -19	24,0	60,0	12,0	24	27
RD NW 13 IR VA	pribl. 1 bar	PN 315	G 1/2" -14	32,0	72,0	15,0	32	36
RD NW 20 IR VA	pribl. 1 bar	PN 250	G 3/4" -14	41,0	84,0	16,5	41	46
RD NW 25 IR VA	pribl. 1 bar	PN 250	G 1" -11	46,0	95,0	19,0	46	50
RD NW 32 IR VA	pribl. 1 bar	PN 250	G 1,1/4" -11	60,0	110,0	21,5	60	60
RD NW 40 IR VA	pribl. 1 bar	PN 250	G 1,1/2" -11	65,0	114,0	22,0	65	70
RD NW 50 IR VA	pribl. 1 bar	PN 250	G 2" -11	-	120,0	26,0	75	75

PN = Menovitý tlak PB = Max. prevádzkový tlak – SW, S1, S2 = Šírka kľúča

Varianty produktu

RD IR	Spätňý ventil, prípojka, Oceľ
-------	-------------------------------