

# AFS G M (3000 PSI)

## Príruba k naskrutkovaniu SAE, BSP

### Vlastnosti

Rad tlakov	3000 psi
Norma	SAE J 518 C ISO 6162
Vyhotovenie	priame
Konštrukcia	Príruba k naskrutkovaniu SAE
Upevnenie	Otvor pre skrutku
Rozsah dodávky	so súpravou metrických skrutiek a O-kružkom
Materiál	S355J2G3 (ST52.3)
Povrchová ochrana	čierno olejovaná

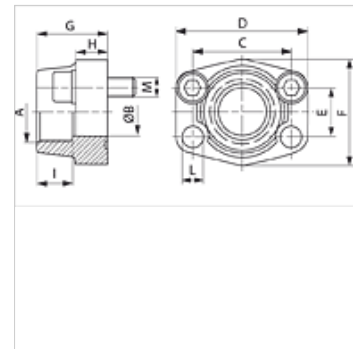

### Poznámka

Uvedený maximálny prevádzkový tlak sa vzťahuje na prírubu! Skutočný prevádzkový tlak je daný rúrkou (hrúbka steny) a rovnako akosťou rúrky!

### Výrobok

Označenie	PB 10.9 (bar)	Veľkosť	A:	Ø B (mm)	C (mm)	D: (mm)	E (mm)	F (mm)	G (mm)	V (mm)	I (mm)	D (mm)	M metr.
AFS 80 G 3/8 M	350	1/2"	G 3/8" -19	13	38,1	54	17,5	46	36	16	19	9,0	M 8 x 30
AFS 80 G 1/2 M	350	1/2"	G 1/2" -14	13	38,1	54	17,5	46	36	16	19	9,0	M 8 x 30
AFS 100 G 1/2 M	350	3/4"	G 1/2" -14	13	47,6	65	22,2	50	36	18	19	11,0	M 10 x 35
AFS 100 G 3/4 M	350	3/4"	G 3/4" -14	19	47,6	65	22,2	50	36	18	19	11,0	M 10 x 35
AFS 102 G 1/2 M	315	1"	G 1/2" -14	13	52,4	70	26,2	55	38	18	22	11,0	M 10 x 35
AFS 102 G 3/4 M	315	1"	G 3/4" -14	19	52,4	70	26,2	55	35	21	19	11,0	M 10 x 35
AFS 102 G 1 M	315	1"	G 1" -11	25	52,4	70	26,2	55	38	18	22	11,0	M 10 x 35
AFS 104 G 3/4 M	250	1.1/4"	G 3/4" -14	19	58,7	79	30,2	68	41	21	22	11,5	M 10 x 40
AFS 104 G 1 M	250	1.1/4"	G 1" -11	25	58,7	81	30,2	65	42	25	22	11,5	M 10 x 40
AFS 104 G 1 M M 12	250	1.1/4"	G 1" -11	25	58,7	81	30,2	65	42	25	22	13,0	M 12 x 40
AFS 104 G 1 1/4 M	250	1.1/4"	G 1,1/4" -11	32	58,7	79	30,2	68	41	21	22	11,5	M 10 x 40
AFS 104 G 1 1/4 M M 12	250	1.1/4"	G 1,1/4" -11	32	58,7	79	30,2	68	41	21	22	13,0	M 12 x 40
AFS 106 G 3/4 M	200	1.1/2"	G 3/4" -14	19	69,9	93	35,7	78	45	25	24	13,5	M 12 x 45
AFS 106 G 1 M	200	1.1/2"	G 1" -11	25	69,9	93	35,7	78	45	25	24	13,5	M 12 x 45
AFS 106 G 1 1/4 M	200	1.1/2"	G 1,1/4" -11	32	69,9	95	35,7	78	45	27	24	13,5	M 12 x 45
AFS 106 G 1 1/2 M	200	1.1/2"	G 1,1/2" -11	38	69,9	93	35,7	78	45	25	24	13,5	M 12 x 45
AFS 108 G 1 M	200	2"	G 1" -11	25	77,8	102	42,9	90	45	25	26	13,5	M 12 x 45
AFS 108 G 1 1/4 M	200	2"	G 1,1/4" -11	32	77,8	102	42,9	90	45	25	24	13,5	M 12 x 45
AFS 108 G 1 1/2 M	200	2"	G 1,1/2" -11	38	77,8	102	42,9	90	45	25	26	13,5	M 12 x 45
AFS 108 G 2 M	200	2"	G 2" -11	51	77,8	102	42,9	90	45	25	30	13,5	M 12 x 45
AFS 110 G 1 1/2 M	160	2.1/2"	G 1,1/2" -11	38	88,9	114	50,8	105	50	25	30	13,5	M 12 x 45
AFS 110 G 2 M	160	2.1/2"	G 2" -11	51	88,9	114	50,8	105	50	25	30	13,5	M 12 x 45
AFS 110 G 2 1/2 M	160	2.1/2"	G 2,1/2" -11	63	88,9	114	50,8	105	50	25	30	13,5	M 12 x 45
AFS 112 G 2 1/2 M	138	3"	G 2,1/2" -11	63	106,4	134	61,9	124	50	27	30	17,5	M 16 x 50
AFS 112 G 3 M	138	3"	G 3" -11	73	106,4	134	61,9	124	50	27	34	17,5	M 16 x 50
AFS 114 G 3 M	35	3.1/2"	G 3" -11	73	120,7	152	69,9	136	48	27	34	17,5	M 16 x 50
AFS 114 G 3 1/2 M	35	3.1/2"	G 3,1/2" -11	89	120,7	152	69,9	136	48	27	34	17,5	M 16 x 50
AFS 116 G 3 1/2 M	35	4"	G 3,1/2" -11	89	130,2	162	77,8	146	48	27	34	17,5	M 16 x 50
AFS 116 G 4 M	35	4"	G 4" -11	99	130,2	162	77,8	146	48	27	34	17,5	M 16 x 50

PN = Menovitý tlak PB = Max. prevádzkový tlak

### Varianty produktu

AFS G (3000 PSI)	Príruba k naskrutkovaniu SAE, BSP, iba prírubu
AFS G U (3000 PSI)	Príruba k naskrutkovaniu SAE, BSP, so súpravou skrutiek UNC a s O-kružkom