

# G VKS ST 250

Štvorhranná príruha Cetop, privarený krúžok

**HANSA FLEX**

## Vlastnosti

**Konštrukcia** Štvorhranná príruha Cetop

**Vyhotovenie** priame

**Norma** CETOP RP 63H  
ISO 6164

**Materiál** S355J2G3 (ST52.3)

**Povrchová ochrana** čierno olejovaná

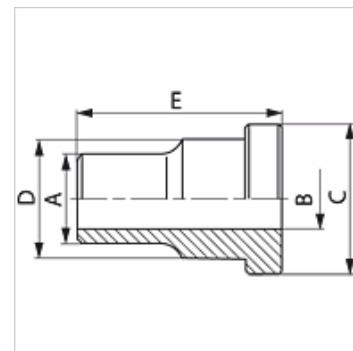
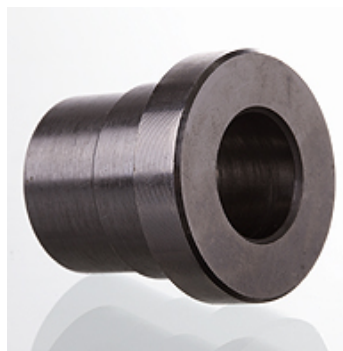

## Výrobok

Označenie	Tlak PB (bar)	Veľkosť	A: (mm)	Ø B (mm)	C (mm)	D: (mm)	E (mm)
<b>G VKS 38 ST 250</b>	250	3/8"	18	12,5	24,5	18,0	30
<b>G VKS 12 ST 250</b>	250	1/2"	22	15,0	30,2	24,0	30
<b>G VKS 34 ST 250</b>	250	3/4"	28	20,0	38,1	31,5	35
<b>G VKS 1 ST 250</b>	250	1"	35	25,0	44,4	38,0	40
<b>G VKS 114 ST 250</b>	250	1.1/4"	43	32,0	50,8	43,0	45
<b>G VKS 112 ST 250</b>	250	1.1/2"	50	38,0	60,3	50,0	50
<b>G VKS 2 ST 250</b>	250	2"	62	47,0	71,4	62,0	60
<b>G VKS 212 ST 250</b>	250	2.1/2"	76	58,0	87,2	76,0	70
<b>G VKS 3 ST 250</b>	250	3"	90	70,0	101,6	90,0	80
<b>G VKS 312 ST 250</b>	250	3.1/2"	102	80,0	119,0	102,0	90
<b>G VKS 4 ST 250</b>	250	4"	114	90,0	131,0	114,0	105

PN = Menovitý tlak PB = Max. prevádzkový tlak – Konštrukčný rad: LL = Veľmi ľahká L = Ľahká S = Ťažká