

G VKS ST 400

Štvorhranná príruha Cetop, privarený krúžok

HANSA FLEX

Vlastnosti

Konštrukcia Štvorhranná príruha Cetop

Vyhotovenie priame

Norma CETOP RP 63H
ISO 6164

Materiál S355J2G3 (ST52.3)

Povrchová ochrana čierne olejovaná

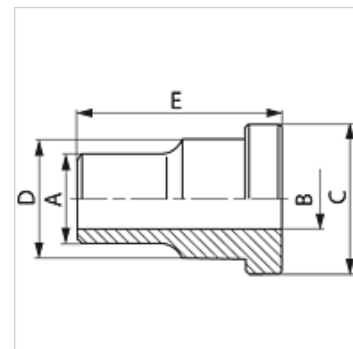

Výrobok

Označenie	Tlak PB (bar)	Veľkosť	A: (mm)	Ø B (mm)	C (mm)	D: (mm)	E (mm)
G VKS 38 ST 400	400	3/8"	18	11,0	26,0	18	35
G VKS 12 ST 400	400	1/2"	22	14,0	31,8	24	40
G VKS 34 ST 400	400	3/4"	28	18,0	39,5	32	45
G VKS 1 ST 400	400	1"	35	22,0	47,6	38	50
G VKS 114 ST 400	400	1.1/4"	44	29,0	54,0	44	55
G VKS 112 ST 400	400	1.1/2"	51	35,0	63,5	51	60
G VKS 2 ST 400	400	2"	61	43,0	79,4	67	70
G VKS 212 ST 400	400	2.1/2"	80	53,0	94,2	60	80
G VKS 3 ST 400	400	3"	90	58,0	104,0	90	90
G VKS 312 ST 400	400	3.1/2"	102	63,0	119,0	102	90
G VKS 4 ST 400	400	4"	114	74,0	131,0	114	105

Konštrukčný rad: LL = Veľmi ľahká L = Ľahká S = Ťažká - PN = Menovitý tlak PB = Max. prevádzkový tlak