

# FHM 90

Uzatváracia skrutka, s vnútorným šesťhranom

**HANSA FLEX**

## Vlastnosti

Prípojka 1	metrický vonkajší závit valcový
Tvar tesnenia 1	Tvar A
Konštrukcia	Uzatváracia skrutka, s vnútorným šesťhranom
Vyhotovenie	priame
Norma	DIN 908
Materiál	Oceľ
Povrchová ochrana	galvanický povlak

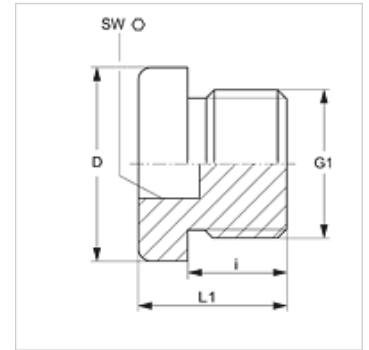

## Výrobok

Označenie	G1	D: (mm)	i (mm)	L1 (mm)	SW (mm)
FHM 90-10	M 10 x 1	14	8	11	5
FHM 90-12	M 12 x 1,5	17	12	15	6
FHM 90-14	M 14 x 1,5	19	12	15	6
FHM 90-16	M 16 x 1,5	21	12	15	8
FHM 90-18	M 18 x 1,5	23	12	16	8
FHM 90-20	M 20 x 1,5	25	14	18	10
FHM 90-22	M 22 x 1,5	27	14	18	10
FHM 90-24	M 24 x 1,5	29	14	18	12
FHM 90-26	M 26 x 1,5	31	16	20	12
FHM 90-30-1.5	M 30 x 1,5	36	16	20	17
FHM 90-36-1.5	M 36 x 1,5	42	16	21	19
FHM 90-42-1.5	M 42 x 1,5	49	16	21	22
FHM 90-48-1.5	M 48 x 1,5	55	16	21	24
FHM 90-52-1.5	M 52 x 1,5	60	16	21	24

PN = Menovitý tlak PB = Max. prevádzkový tlak