

# EWORC 45

Nákrutka k naskrutkovaniu, uhol 45°

**HANSA FLEX**

## Vlastnosti

Prípojka 1	Vonkajší závit BSP, valcový
Tvar tesnenia 1	O-krúžok a komorový krúžok
Prípojka 2	metrický vonkajší závit valcový
Tvar tesnenia 2	Vnútorný kužeľ 24°
Konštrukcia	Nákrutka pre naskrutkovanie s nastaviteľným smerom
Vyhotovenie	Uhol 45°
Rozsah dodávky	Hrdlo s presuvnou maticou a zárezným krúžkom
Materiál	Oceľ
Povrchová ochrana	galvanický povlak

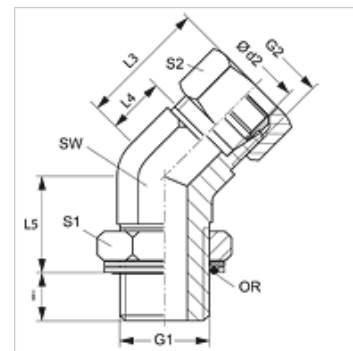

## Poznámka

Pokyny pre montáž, zabudovanie, tlakové zaťaženie a povolené prevádzkové teploty nájdete v technických informáciách pre fittingové nákrutky

## Výrobok

Označenie	Konštrukčný rad	Prevádzkový tlak	Ø d2	G1	G2	i	L3	L4	L5	SW	S1	S2	OR
			(mm)			(mm)	(mm)	(mm)	(mm)	(mm)			
EWORC 45 NW 04 HL	D	PN 315	6	G 1/8" -28	M 12 x 1,5	7	24	9	21	14	14	14	7,97 x 1,88
EWORC 45 NW 06 HL	D	PN 315	8	G 1/4" -19	M 14 x 1,5	9	27	12	20	14	19	17	10,77 x 2,62
EWORC 45 NW 08 HL	D	PN 315	10	G 1/4" -19	M 16 x 1,5	9	27	12	25	19	19	19	10,77 x 2,62
EWORC 45 NW 10 HL	D	PN 250	12	G 3/8" -19	M 18 x 1,5	9	28	14	28	19	22	22	13,94 x 2,62
EWORC 45 NW 13 HL	D	PN 250	15	G 1/2" -14	M 22 x 1,5	13	32	17	26	22	27	27	17,86 x 2,62
EWORC 45 NW 16 HL	D	PN 250	18	G 1/2" -14	M 26 x 1,5	13	33	17	32	27	27	32	17,86 x 2,62
EWORC 45 NW 20 HL	D	PN 160	22	G 3/4" -14	M 30 x 2	13	35	19	37	30	36	36	23,47 x 2,62
EWORC 45 NW 25 HL	D	PN 160	28	G 1" -11	M 36 x 2	15	40	23	37	36	41	41	29,74 x 3,53
EWORC 45 NW 32 HL	D	PN 160	35	G 1,1/4" -11	M 45 x 2	15	48	27	39	50	50	50	37,69 x 3,53
EWORC 45 NW 40 HL	D	PN 160	42	G 1,1/2" -11	M 52 x 2	15	49	26	39	50	55	60	44,04 x 3,53
EWORC 45 NW 03 HS	S	PN 315	6	G 1/4" -19	M 14 x 1,5	9	24	9	19	14	19	17	10,77 x 2,62
EWORC 45 NW 04 HS	S	PN 315	8	G 1/4" -19	M 16 x 1,5	9	27	12	23	19	19	19	10,77 x 2,62
EWORC 45 NW 06 HS	S	PN 250	10	G 3/8" -19	M 18 x 1,5	9	29	13	25	19	22	22	13,94 x 2,62
EWORC 45 NW 08 HS	S	PN 250	12	G 3/8" -19	M 20 x 1,5	9	33	17	25	22	22	24	13,94 x 2,62
EWORC 45 NW 13 HS	S	PN 250	16	G 1/2" -14	M 24 x 1,5	13	34	16	31	27	27	30	17,86 x 2,62
EWORC 45 NW 16 HS	S	PN 250	20	G 3/4" -14	M 30 x 2	12	38	16	34	30	36	36	23,47 x 2,62
EWORC 45 NW 20 HS	S	PN 250	25	G 1" -11	M 36 x 2	14	43	19	37	36	41	46	29,74 x 3,53
EWORC 45 NW 25 HS	S	PN 160	30	G 1,1/4" -11	M 42 x 2	15	50	24	38	50	50	50	37,69 x 3,53
EWORC 45 NW 32 HS	S	PN 160	38	G 1,1/2" -11	M 52 x 2	15	52	21	38	50	55	60	44,04 x 3,53

Konštrukčný rad: LL = Veľmi ľahká L = Ľahká S = Ťažká - PN = Menovitý tlak PB = Max. prevádzkový tlak - Ø d2 = Vonkajší priemer rúry

## Varianty produktu

**XEWORK 45** Nákrutka k naskrutkovaniu, uhol 45°, Hrdlo (bez presuvnej matice a zárezného krúžku)