

WN VA

Nákrutka k naskrutkovaniu, uhol 90°

HANSA FLEX

Vlastnosti

Prípojka 1	Vonkajší závit NPT
Tvar tesnenia 1	tesniaci závit
Prípojka 2	metrický vonkajší závit valcový
Tvar tesnenia 2	Vnútorný kužeľ 24°
Konštrukcia	Nákrutka pre naskrutkovanie
Vyhotovenie	Uhol 90°
Norma	DIN 2353 ISO 8434-1
Rozsah dodávky	Hrdlo s presuvnou maticou a zárezným krúžkom
Materiál	Ušľachtilá oceľ

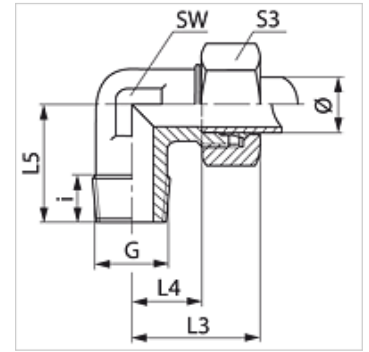

Poznámka

Pokyny pre montáž, zabudovanie, tlakové zaťaženie a povolené prevádzkové teploty nájdete v technických informáciách pre fittingové nákrutky

Výrobok

Označenie	Konštrukčný rad	Prevádzkový tlak	Rúrka, vonkajší Ø (mm)	G	i (mm)	L3 (mm)	L4 (mm)	L5 (mm)	SW (mm)	S3
WN 04 LL VA	LL	PN 100	4	1/8" -27 NPT	7,0	21	11,0	17	9	10
WN 06 LL VA	LL	PN 100	6	1/8" -27 NPT	10,0	21	9,5	17	9	12
WN 08 LL VA	LL	PN 100	8	1/8" -27 NPT	10,0	21	9,5	17	12	14
WN NW 04 HL VA	D	PN 315	6	1/8" -27 NPT	10,0	27	12,0	20	12	14
WN NW 04 HL 1/4 VA	D	PN 315	6	1/4" -18 NPT	12,0	29	14,0	26	12	14
WN NW 04 HL 3/8 VA	D	PN 315	6	3/8" -18 NPT	15,3	33	18,0	28	14	14
WN NW 04 HL 1/2 VA	D	PN 315	6	1/2" -14 NPT	17,0	38	23,0	34	19	14
WN NW 06 HL 1/8 VA	D	PN 315	8	1/8" -27 NPT	110,0	29	14,0	26	12	17
WN NW 06 HL VA	D	PN 315	8	1/4" -18 NPT	12,0	29	14,0	26	12	17
WN NW 06 HL 3/8 VA	D	PN 315	8	3/8" -18 NPT	15,2	23	11,5	20	12	17
WN NW 06 HL 1/2 VA	D	PN 315	8	1/2" -14 NPT	17,5	30	15,0	26	12	17
WN NW 08 HL 1/8 VA	D	PN 315	10	1/8" -27 NPT	10,0	30	15,0	27	14	19
WN NW 08 HL VA	D	PN 315	10	1/4" -18 NPT	14,0	30	15,0	27	14	19
WN NW 08 HL 3/8 VA	D	PN 315	10	3/8" -18 NPT	15,2	30	15,0	27	14	19
WN NW 08 HL 1/2 VA	D	PN 315	10	1/2" -14 NPT	20,0	37	21,0	33	17	19
WN NW 10 HL 1/4 VA	D	PN 315	12	1/4" -18 NPT	14,0	32	17,0	28	17	22
WN NW 10 HL VA	D	PN 315	12	3/8" -18 NPT	12,5	32	17,0	28	17	22
WN NW 10 HL 1/2 VA	D	PN 315	12	1/2" -14 NPT	19,0	38	23,0	34	19	22
WN NW 13 HL 3/8 VA	D	PN 315	15	3/8" -18 NPT	13,0	36	21,0	34	19	27
WN NW 13 HL VA	D	PN 315	15	1/2" -14 NPT	18,5	36	21,0	34	19	27
WN NW 16 HL 3/8 VA	D	PN 315	18	3/8" -18 NPT	15,3	40	23,5	36	24	32
WN NW 16 HL VA	D	PN 315	18	1/2" -14 NPT	20,0	40	23,5	36	24	32
WN NW 16 HL 3/4 VA	D	PN 315	18	3/4" -14 NPT	18,5	40	23,5	40	24	32
WN NW 20 HL 1/2 VA	D	PN 160	22	1/2" -14 NPT	20,0	44	27,5	42	27	36
WN NW 20 HL VA	D	PN 160	22	3/4" -14 NPT	18,5	44	27,5	42	27	36
WN NW 25 HL 3/4 VA	D	PN 160	28	3/4" -14 NPT	20,0	47	30,5	48	36	41
WN NW 25 HL VA	D	PN 160	28	1" -11,5 NPT	24,0	47	30,5	48	36	41
WN NW 32 HL VA	D	PN 160	35	1,1/4" -11,5 NPT	25,5	56	34,5	54	41	50
WN NW 40 HL VA	D	PN 160	42	1,1/2" -11,5 NPT	26,0	63	40,0	61	50	60
WN NW 03 HS VA	S	PN 630	6	1/4" -18 NPT	12,0	31	16,0	26	12	17
WN NW 03 HS 3/8 VA	S	PN 630	6	3/8" -18 NPT	15,3	32	17,5	27	14	17
WN NW 03 HS 1/2 VA	S	PN 630	6	1/2" -14 NPT	20,0	36	21,0	34	17	17
WN NW 04 HS VA	S	PN 630	8	1/4" -18 NPT	15,0	32	17,0	27	14	19
WN NW 04 HS 3/8 VA	S	PN 630	8	3/8" -18 NPT	15,3	33	18,0	28	14	19
WN NW 04 HS 1/2 VA	S	PN 630	8	1/2" -14 NPT	20,0	38	23,0	34	17	19
WN NW 06 HS 1/4 VA	S	PN 630	10	1/4" -18 NPT	15,0	34	17,5	28	17	22
WN NW 06 HS VA	S	PN 630	10	3/8" -18 NPT	12,0	34	17,5	28	17	22
WN NW 06 HS 1/2 VA	S	PN 630	10	1/2" -14 NPT	20,0	39	22,5	32	17	22
WN NW 08 HS 1/4 VA	S	PN 630	12	1/4" -18 NPT	15,0	38	21,5	29	17	24
WN NW 08 HS VA	S	PN 630	12	3/8" -18 NPT	12,5	38	21,5	28	17	24
WN NW 08 HS 1/2 VA	S	PN 630	12	1/2" -14 NPT	20,0	39	21,5	34	17	24
WN NW 10 HS 3/8 VA	S	PN 630	14	3/8" -18 NPT	15,3	40	22,0	30	19	27



Napriek čo najstarostlivejšej kontrole nemôžeme vylúčiť chyby a nepreberáme žiadnu záruku za zahrnuté údaje.

04.04.2025

HANSA-FLEX AG

www.hansa-flex.com

1

WN VA

Nákrutka k naskrutkovaniu, uhol 90°

HANSA FLEX

Výrobok

Označenie	Konstrukčný rad	Prevádzkový tlak	Rúrka, vonkajší Ø (mm)	G	i (mm)	L3 (mm)	L4 (mm)	L5 (mm)	SW (mm)	S3
WN NW 10 HS VA	S	PN 630	14	1/2" -14 NPT	18,0	40	22,0	34	19	27
WN NW 13 HS 3/8 VA	S	PN 400	16	3/8" -18 NPT	15,3	43	24,5	32	24	30
WN NW 13 HS VA	S	PN 400	16	1/2" -14 NPT	19,0	43	24,5	36	24	30
WN NW 13 HS 3/4 VA	S	PN 400	16	3/4" -14 NPT	20,0	43	25,0	40	24	30
WN NW 16 HS 1/2 VA	S	PN 400	20	1/2" -14 NPT	20,0	48	26,5	42	27	36
WN NW 16 HS VA	S	PN 400	20	3/4" -14 NPT	20,0	48	26,6	42	27	36
WN NW 20 HS VA	S	PN 400	25	1" -11,5 NPT	24,0	54	30,0	48	36	46
WN NW 25 HS VA	S	PN 400	30	1,1/4" -11,5 NPT	25,5	62	35,5	54	41	50
WN NW 32 HS VA	S	PN 315	38	1,1/2" -11,5 NPT	26,0	72	41,0	61	50	60

PN = Menovitý tlak PB = Max. prevádzkový tlak – Konštrukčný rad: LL = Veľmi ľahká L = Ľahká S = Ťažká – Ø = Vonkajší priemer rúrky

Varianty produktu

WN	Nákrutka k naskrutkovaniu, uhol 90°, Oceľ
WN MG	Nákrutka k naskrutkovaniu, uhol 90°, Mosadz
XWN VA	Nákrutka k naskrutkovaniu, uhol 90°, Ušľachtilá oceľ