

Vlastnosti

Prípojka 1	Vonkajší závit kužeľový BSPT
Tvar tesnenia 1	tesniaci závit
Prípojka 2	metrický vonkajší závit valcový
Tvar tesnenia 2	Vnútorý kužeľ 24°
Konštrukcia	Nákrutka pre naskrutkovanie
Vyhotovenie	Uhol 90°
Norma	DIN 2353 ISO 8434-1
Rozsah dodávky	Hrdlo s presuvnou maticou a zárezným krúžkom
Materiál	Mosadz

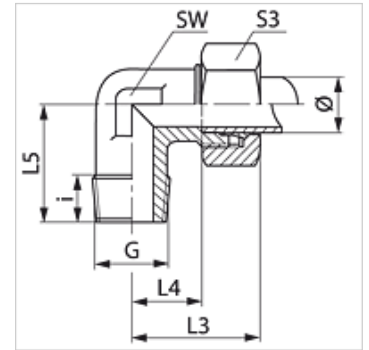

Poznámka

Pokyny pre montáž, zabudovanie, tlakové zaťaženie a povolené prevádzkové teploty nájdete v technických informáciách pre fittingové nákrutky

Výrobok

Označenie	Konštrukčný rad	Prevádzkový tlak	Rúrka, vonkajší Ø (mm)	G	i (mm)	L3 (mm)	L4 (mm)	L5 (mm)	SW (mm)	S3
WR 04 LL MG	LL	PN 63	4	R 1/8" K	8	21	11,0	18	11	10
WR 05 LL MG	LL	PN 63	5	R 1/8" K	8	22	10,0	17	11	12
WR 06 LL MG	LL	PN 63	6	R 1/8" K	8	22	10,0	17	11	12
WR 08 LL MG	LL	PN 63	8	R 1/8" K	8	23	11,5	20	12	14
WR 10 LL MG	LL	PN 63	10	R 1/4" K	12	27	15,5	26	14	17
WR 12 LL MG	LL	PN 63	12	R 1/4" K	12	27	15,0	27	17	19
WR NW 04 HL MG	D	PN 200	6	R 1/8" K	8	27	12,0	20	12	14
WR NW 04 HL 1/4 MG	D	PN 200	6	R 1/4" K	12	29	14,0	26	12	14
WR NW 06 HL MG	D	PN 200	8	R 1/4" K	12	29	14,0	26	12	17
WR NW 08 HL MG	D	PN 200	10	R 1/4" K	12	30	15,0	27	14	19
WR NW 10 HL MG	D	PN 200	12	R 3/8" K	12	32	17,0	28	17	22
WR NW 10 HL 1/4 MG	D	PN 200	12	R 1/4" K	12	32	17,0	28	17	22
WR NW 10 HL 1/2 MG	D	PN 200	12	R 1/2" K	14	38	23,0	34	19	22
WR NW 13 HL MG	D	PN 200	15	R 1/2" K	14	36	21,0	34	19	27
WR NW 16 HL MG	D	PN 200	18	R 1/2" K	14	40	23,5	36	24	32
WR NW 03 HS MG	S	PN 250	6	R 1/4" K	12	31	16,0	26	12	17
WR NW 04 HS MG	S	PN 250	8	R 1/4" K	12	32	17,0	27	17	19
WR NW 06 HS MG	S	PN 250	10	R 3/8" K	12	34	17,5	28	17	22
WR NW 13 HS MG	S	PN 250	16	R 1/2" K	14	43	24,5	32	24	30

Konštrukčný rad: LL = Veľmi ľahká L = Ľahká S = Ťažká – PN = Menovitý tlak PB = Max. prevádzkový tlak – Ø = Vonkajší priemer rúrky

Varianty produktu

WRK	Nákrutka k naskrutkovaniu, uhol 90°, Oceľ
WRK VA	Nákrutka k naskrutkovaniu, uhol 90°, Ušľachtilá oceľ