

WRK VA

Nákrutka k naskrutkovaniu, uhol 90°

HANSA FLEX

Vlastnosti

Prípojka 1	Vonkajší závit kužeľový BSPT
Tvar tesnenia 1	tesniaci závit
Prípojka 2	metrický vonkajší závit valcový
Tvar tesnenia 2	Vnútorný kužeľ 24°
Konštrukcia	Nákrutka pre naskrutkovanie
Vyhotovenie	Uhol 90°
Norma	DIN 2353 ISO 8434-1
Rozsah dodávky	Hrdlo s presuvnou maticou a zárezným krúžkom
Materiál	Ušľachtilá oceľ

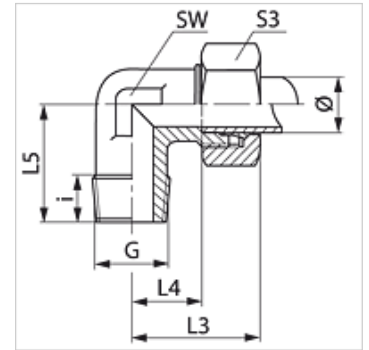

Poznámka

Pokyny pre montáž, zabudovanie, tlakové zaťaženie a povolené prevádzkové teploty nájdete v technických informáciách pre fittingové nákrutky

Výrobok

Označenie	Konštrukčný rad	Prevádzkový tlak	Rúrka, vonkajší Ø (mm)	G	i (mm)	L3 (mm)	L4 (mm)	L5 (mm)	SW (mm)	S3
WR 04 LL VA	LL	PN 100	4	R 1/8" K	8	21,0	11,0	18	11	10
WR 06 LL VA	LL	PN 100	6	R 1/8" K	8	22,0	10,0	17	11	12
WR 08 LL VA	LL	PN 100	8	R 1/8" K	8	23,0	11,5	20	12	14
WR NW 04 HL VA	D	PN 315	6	R 1/8" K	8	27,0	12,0	20	12	14
WR NW 04 HL 1/4 VA	D	PN 315	6	R 1/4" K	12	29,0	14,0	26	12	14
WR NW 04 HL 3/8 VA	D	PN 315	6	R 3/8" K	12	29,0	14,0	26	12	14
WR NW 04 HL 1/2 VA	D	PN 315	6	R 1/2" K	14	30,5	15,5	30	17	14
WR NW 06 HL 1/8 VA	D	PN 315	8	R 1/8" K	8	29,0	14,0	26	12	17
WR NW 06 HL VA	D	PN 315	8	R 1/4" K	12	29,0	14,0	26	12	17
WR NW 06 HL 3/8 VA	D	PN 315	8	R 3/8" K	12	34,0	19,0	28	17	17
WR NW 06 HL 1/2 VA	D	PN 315	8	R 1/2" K	13	34,0	19,0	30	17	17
WR NW 08 HL 1/8 VA	D	PN 315	10	R 1/8" K	8	30,0	15,0	26	14	19
WR NW 08 HL VA	D	PN 315	10	R 1/4" K	12	30,0	15,0	27	14	19
WR NW 08 HL 3/8 VA	D	PN 315	10	R 3/8" K	12	32,0	17,0	28	17	19
WR NW 08 HL 1/2 VA	D	PN 316	10	R 1/2" K	14	38,0	23,0	34	19	19
WR NW 10 HL 1/8 VA	D	PN 315	12	R 1/8" K	8	32,0	17,5	27	17	22
WR NW 10 HL 1/4 VA	D	PN 315	12	R 1/4" K	12	32,0	17,0	28	17	22
WR NW 10 HL VA	D	PN 315	12	R 3/8" K	12	32,0	17,0	28	17	22
WR NW 10 HL 1/2 VA	D	PN 315	12	R 1/2" K	14	38,0	23,0	34	19	22
WR NW 13 HL 1/4 VA	D	PN 315	15	R 1/4" K	12	36,0	21,0	30	19	27
WR NW 13 HL 3/8 VA	D	PN 315	15	R 3/8" K	12	36,0	21,0	34	19	27
WR NW 13 HL VA	D	PN 315	15	R 1/2" K	14	36,0	21,0	34	19	27
WR NW 13 HL 3/4 VA	D	PN 160	15	R 3/4" K	16	36,0	21,0	34	24	27
WR NW 16 HL 3/8 VA	D	PN 315	18	R 3/8" K	12	40,0	23,5	34	24	32
WR NW 16 HL VA	D	PN 315	18	R 1/2" K	14	40,0	23,5	36	24	32
WR NW 16 HL 3/4 VA	D	PN 160	18	R 3/4" K	16	36,0	27,5	44	27	32
WR NW 20 HL 1/2 VA	D	PN 160	22	R 1/2" K	14	44,0	27,5	41	27	36
WRK NW 20 HL VA	D	PN 160	22	R 3/4" K	16	44,0	27,5	31	27	36
WRK NW 25 HL VA	D	PN 160	28	R 1" K	20	51,5	30,5	47	36	41
WR NW 03 HS 1/8 VA	S	PN 400	6	R 1/8" K	8	29,5	15,0	25	8	12
WR NW 03 HS VA	S	PN 400	6	R 1/4" K	12	31,0	16,0	26	12	17
WR NW 03 HS 3/8 VA	S	PN 400	6	R 3/8" K	12	32,0	17,5	27	14	17
WR NW 03 HS 1/2 VA	S	PN 400	6	R 1/2" K	14	34,0	19,0	33	17	17
WR NW 04 HS VA	S	PN 400	8	R 1/4" K	12	32,0	17,0	27	17	19
WR NW 04 HS 3/8 VA	S	PN 400	8	R 3/8" K	12	33,0	18,0	28	14	19
WR NW 04 HS 1/2 VA	S	PN 400	8	R 1/2" K	14	38,0	23,0	33	17	19
WR NW 06 HS 1/4 VA	S	PN 400	10	R 1/4" K	12	34,0	17,5	28	17	22
WR NW 06 HS VA	S	PN 400	10	R 3/8" K	12	34,0	17,5	28	17	22
WR NW 06 HS 1/2 VA	S	PN 400	10	R 1/2" K	14	39,0	22,5	32	17	22
WR NW 08 HS 1/4 VA	S	PN 400	12	R 1/4" K	12	38,0	21,5	27	17	24
WR NW 08 HS VA	S	PN 400	12	R 3/8" K	12	38,0	21,5	28	17	24
WR NW 08 HS 1/2 VA	S	PN 400	12	R 1/2" K	14	40,0	23,5	34	19	24



Napriek čo najstarostlivejšej kontrole nemôžeme vylúčiť chyby a nepreberáme žiadnu záruku za zahnuté údaje.

14.04.2025

HANSA-FLEX AG

www.hansa-flex.com

1

Výrobok

Označenie	Konštrukčný rad	Prevádzkový tlak	Rúrka, vonkajší Ø (mm)	G	i (mm)	L3 (mm)	L4 (mm)	L5 (mm)	SW (mm)	S3
WR NW 10 HS 3/8 VA	S	PN 400	14	R 3/8" K	12	40,0	22,0	30	19	27
WR NW 10 HS VA	S	PN 400	14	R 1/2" K	14	40,0	22,0	32	19	27
WR NW 13 HS 3/8 VA	S	PN 400	16	R 3/8" K	12	43,0	24,5	32	24	30
WR NW 13 HS VA	S	PN 400	16	R 1/2" K	14	43,0	24,5	32	24	30
WR NW 13 HS 3/4 VA	S	PN 160	16	R 3/4" K	16	43,0	24,5	41	24	30
WR NW 16 HS 1/2 VA	S	PN 400	20	R 1/2" K	14	48,0	26,5	42	27	36
WRK NW 16 HS VA	S	PN 160	20	R 3/4" K	16	48,0	26,5	42	27	36

Konštrukčný rad: LL = Veľmi ľahká L = Ľahká S = Ťažká – PN = Menovitý tlak PB = Max. prevádzkový tlak – Ø = Vonkajší priemer rúrky

Varianty produktu

WRK	Nákrutka k naskrutkovaniu, uhol 90°, Oceľ
WRK MG	Nákrutka k naskrutkovaniu, uhol 90°, Mosadz
XWRK VA	Nákrutka k naskrutkovaniu, uhol 90°, Ušľachtilá oceľ