

GE HN AB VA

Hrdlo k naskrutkovaniu

Vlastnosti

Prípojka 1	Vonkajší závit NPT
Tvar tesnenia 1	tesniaci závit
Prípojka 2	Závit pre matice BSP
Tvar tesnenia 2	Vnútorý kužel 60°
Konštrukcia	Hrdlo k zaskrutkovaniu
Vyhotovenie	priame
Materiál	Ušľachtilá oceľ

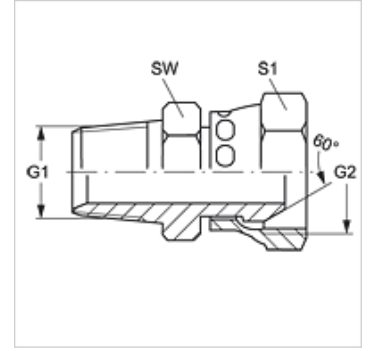

Výrobok

Označenie	G1	G2	SW (mm)	S1
GE HN 02 AB VA	1/8" -27 NPT	G 1/8" -28	14	14
GE HN 04 AB VA	1/4" -18 NPT	G 1/4" -19	16	19
GE HN 04 AB 06 VA	1/4" -18 NPT	G 3/8" -19	18	22
GE HN 06 AB 04 VA	3/8" -18 NPT	G 1/4" -19	21	19
GE HN 06 AB VA	3/8" -18 NPT	G 3/8" -19	22	22
GE HN 06 AB 08 VA	3/8" -18 NPT	G 1/2" -14	25	22
GE HN 08 AB 06 VA	1/2" -14 NPT	G 3/8" -19	22	22
GE HN 08 AB VA	1/2" -14 NPT	G 1/2" -14	25	27
GE HN 12 AB 08 VA	3/4" -14 NPT	G 1/2" -14	33	27
GE HN 12 AB VA	3/4" -14 NPT	G 3/4" -14	33	32
GE HN 16 AB 12 VA	1" -11,5 NPT	G 3/4" -14	35	32
GE HN 16 AB VA	1" -11,5 NPT	G 1" -11	38	41
GE HN 20 AB VA	1,1/4" -11,5 NPT	G 1,1/4" -11	46	50
GE HN 24 AB VA	1,1/2" -11,5 NPT	G 1,1/2" -11	50	55
GE HN 32 AB VA	2" -11,5 NPT	G 2" -11	65	70

SW, S1, S2 = Šírka kľúča

Varianty produktu

GE HN AB Hrdlo k naskrutkovaniu, Oceľ